



FORD **PERFORMANCE**

M-F150-FPS7 (Classic)
F-150 (4X4 Regular Cab & 4X2 Regular Cab)
FP700S Package

NO PART OF THIS DOCUMENT MAY BE REPRODUCED WITHOUT PRIOR AGREEMENT AND WRITTEN PERMISSION OF
FORD PERFORMANCE PARTS © Ford Motor Company 2020

PRIOR TO INSTALLATION READ THESE INSTRUCTIONS COMPLETELY
For questions, Call the FORD PERFORMANCE Techline 1-800-367-3788

Please visit <https://www.performanceparts.ford.com> for warranty information



FP700S Black and Bronze Shown, FP700S Classic Similar

Ford Factory Shop Manual purchase options www.motorcraftservice.com



FORD PERFORMANCE

M-F150-FPS7 (Classic)
F-150 (4X4 Regular Cab & 4X2 Regular Cab)
FP700S Package

NO PART OF THIS DOCUMENT MAY BE REPRODUCED WITHOUT PRIOR AGREEMENT AND WRITTEN PERMISSION OF
FORD PERFORMANCE PARTS © Ford Motor Company 2020

Package contents:

Description	Quantity
FP700S Keychain	2
FP700S Interior Badge	1
Ford Performance Exterior Badge	1
'F-150' Tailgate Lettering	1
Bodyside Graphics	1
Hood Graphics	1
Ford Performance Fender Vents Kit	1
22" Wheel Kit	1
Black Lug Nut Kit	1
Rocker Panel Aero Shield Kit	1
Front Lip Splitter	1
5.0L Supercharger Kit	1
FP700S Regular Cab Suspension Kit	1
Rear Lowering Kit	1

Installation Section:

1. [FP700S Interior Badge](#)
2. [Ford Performance Exterior Badge](#)
3. ['F-150' Tailgate Lettering, Non-Split Tailgate](#)
[Split Tailgate](#)
4. [Bodyside Graphics](#)
[6.5 Foot Box](#)
[5.5 Foot Box](#)
5. [Hood Graphics](#)
6. [Ford Performance Fender Vents](#)
7. [Rocker Panel Aero Shield Kit](#)
8. [Front Lip Splitter](#)
9. [5.0L Supercharger](#)
10. [FP700S Regular Cab Suspension Kit](#)
11. [Rear Lowering Kit](#)

Ford Factory Shop Manual purchase options www.motorcraftservice.com



M-F150-FPS7 (Classic)
F-150 (4X4 Regular Cab & 4X2 Regular Cab)
FP700S Package

NO PART OF THIS DOCUMENT MAY BE REPRODUCED WITHOUT PRIOR AGREEMENT AND WRITTEN PERMISSION OF FORD PERFORMANCE PARTS © Ford Motor Company 2020

1. FP700S Interior Badge

Special Tool(s) / General Equipment

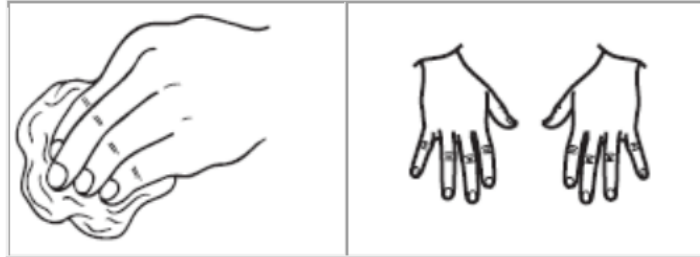

Installation

1. Ideal application temperature range 70°F (21°C) – 100°F (38°C). Do NOT install if temperature is below 50°F (10°C).
2. Wipe surface with isopropyl alcohol.
3. Ensure the surface is dry.
4. Apply badge and press firmly (10-20 pounds per linear inch, PLI) so the adhesive sticks.



Ford Factory Shop Manual purchase options www.motorcraftservice.com



M-F150-FPS7 (Classic)
F-150 (4X4 Regular Cab & 4X2 Regular Cab)
FP700S Package



NO PART OF THIS DOCUMENT MAY BE REPRODUCED WITHOUT PRIOR AGREEMENT AND WRITTEN PERMISSION OF FORD PERFORMANCE PARTS © Ford Motor Company 2020

2. Ford Performance Exterior Badge

Kit contents:

Description	Quantity
FORD PERFORMANCE Performance Badge	1

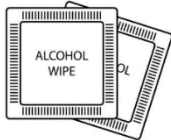
Special Tool(s) / General Equipment:

 Clean rag	 Isopropyl Alcohol	 Tape
--	--	---

Legend



Indicates important note or information to be considered prior to proceeding



Indicates an encountered condition requiring work stoppage

Ford Factory Shop Manual purchase options www.motorcraftservice.com



FORD **PERFORMANCE**

M-F150-FPS7 (Classic)
F-150 (4X4 Regular Cab & 4X2 Regular Cab)
FP700S Package

NO PART OF THIS DOCUMENT MAY BE REPRODUCED WITHOUT PRIOR AGREEMENT AND WRITTEN PERMISSION OF FORD PERFORMANCE PARTS © Ford Motor Company 2020

Installation

1. Using a rag and soap and water, clean the tail gate
2. Using diluted rubbing alcohol (50/50) or an alcohol wipe, remove any remaining residue/dirt.
3. Without removing tape backing, place sill plate on sill in desired location.

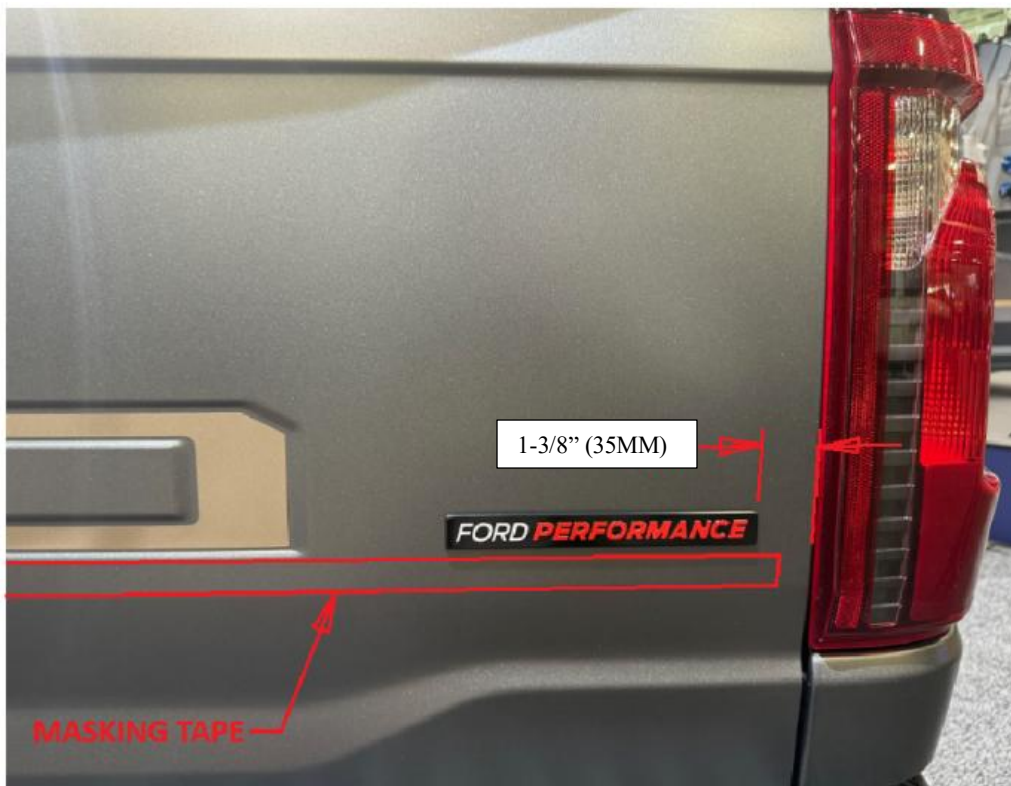

Ford Factory Shop Manual purchase options www.motorcraftservice.com

NO PART OF THIS DOCUMENT MAY BE REPRODUCED WITHOUT PRIOR AGREEMENT AND WRITTEN PERMISSION OF
FORD PERFORMANCE PARTS © Ford Motor Company 2020

4. Place masking tape along the lower tangent of the F150 embossment to the edge of the tail gate. Measure 2” From the edge of the tail gate (Fig A-2)
5. Remove backer of the tape, place on Tail Gate 2” from the RH edge of tail gate and along the top edge of the masking tape.



 **Note: Do not touch the adhesive liner during installation.**

 **Note: Only apply light pressure to ease adjustment.**

6. Once placement and alignment meet desired appearance, begin pressing the badge firmly into place using a clean lint free cloth, starting from the center of the badge and working to the outside edges.



7. Remove protective cover

NO PART OF THIS DOCUMENT MAY BE REPRODUCED WITHOUT PRIOR AGREEMENT AND WRITTEN PERMISSION OF FORD PERFORMANCE PARTS © Ford Motor Company 2020

3. 'F-150' Tailgate Lettering, Non-Split Tailgate

Special Tool(s) / General Equipment



! **NOTE:** The room temperature and surface temperature must be no lower than 68 degrees Fahrenheit (20° C) or higher than 90 degrees Fahrenheit (32° C) to ensure proper installation.

- 3.1 Clean surface with naphtha base cleaner to remove dirt and grease. Remove residue from area and allow area to dry thoroughly.

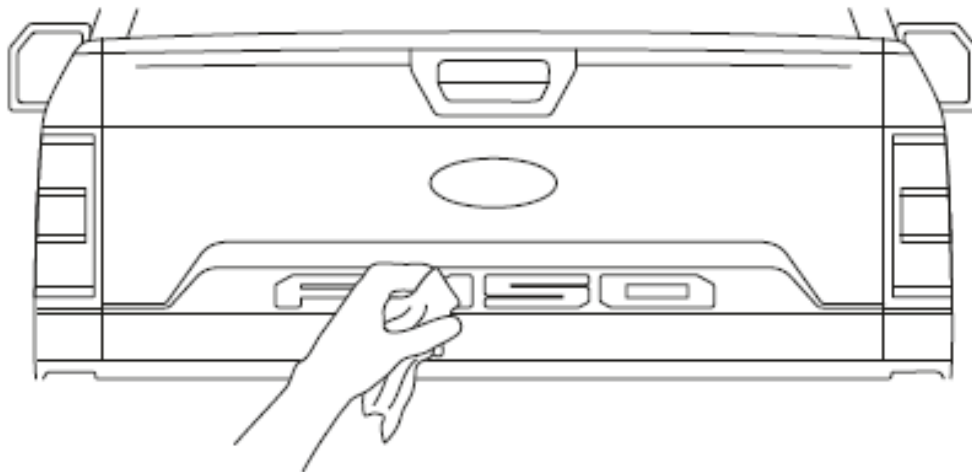



FORD PERFORMANCE

M-F150-FPS7 (Classic)
F-150 (4X4 Regular Cab & 4X2 Regular Cab)
FP700S Package

NO PART OF THIS DOCUMENT MAY BE REPRODUCED WITHOUT PRIOR AGREEMENT AND WRITTEN PERMISSION OF FORD PERFORMANCE PARTS © Ford Motor Company 2020

3.2 Remove the film on the adhesive side of the “F-1” decal. **Carefully** position the “F-1” decal on the tailgate by aligning it with the locations shown with arrows in the illustration below.

LEAVE CARRIER ON.

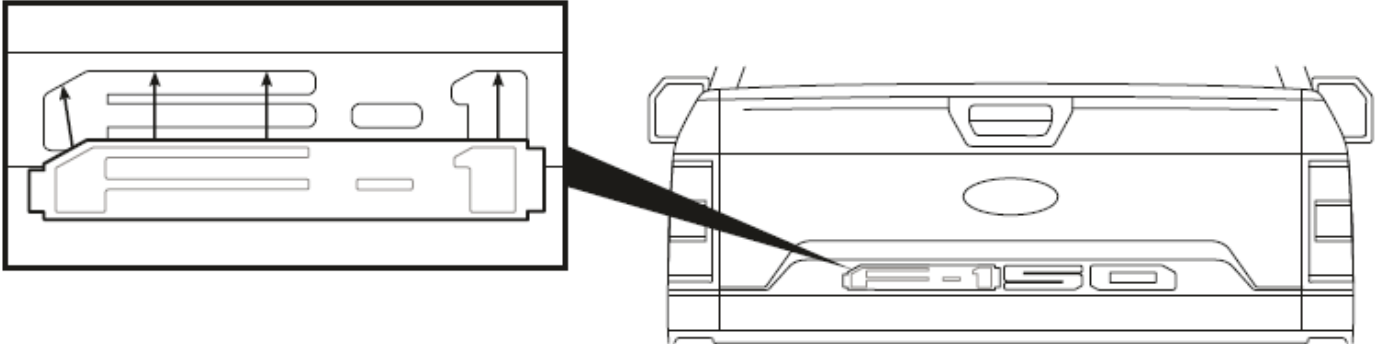

3.3 Use the foam block to firmly press along the directions shown in the illustration below to adhere the decal to the tailgate.

LEAVE CARRIER ON.

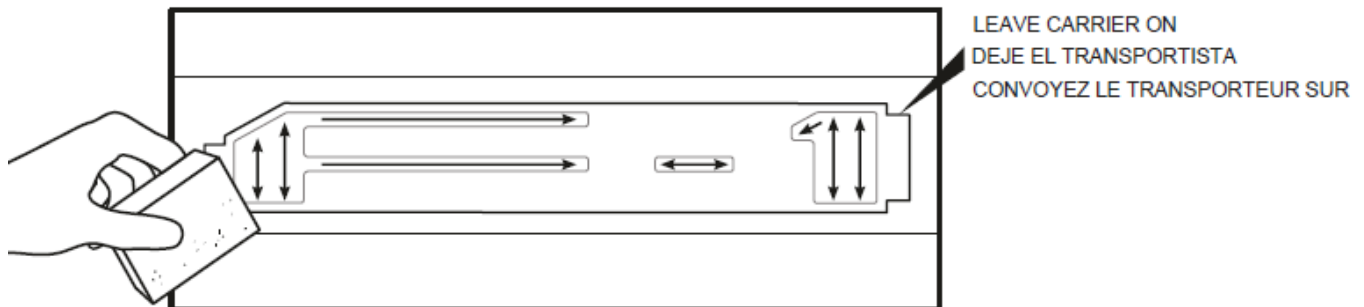

Ford Factory Shop Manual purchase options www.motorcraftservice.com

NO PART OF THIS DOCUMENT MAY BE REPRODUCED WITHOUT PRIOR AGREEMENT AND WRITTEN PERMISSION OF FORD PERFORMANCE PARTS © Ford Motor Company 2020

3.4 Remove the film on the adhesive side of the “50” decal. **Carefully** position the “50” decal on the tailgate by aligning it with the “F-1” carrier and locations shown with arrows in the illustration below.

LEAVE CARRIER ON.

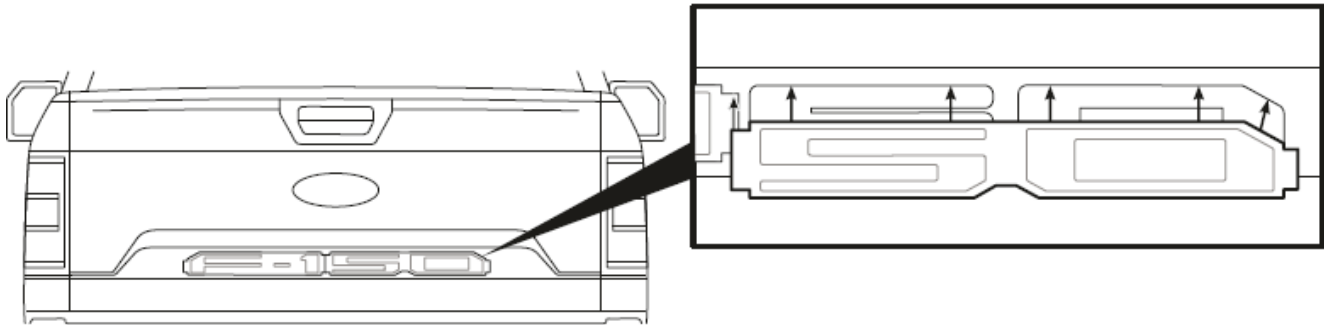

3.5 Use the foam block to firmly press along the directions shown in the illustration below to adhere the decal to the tailgate.

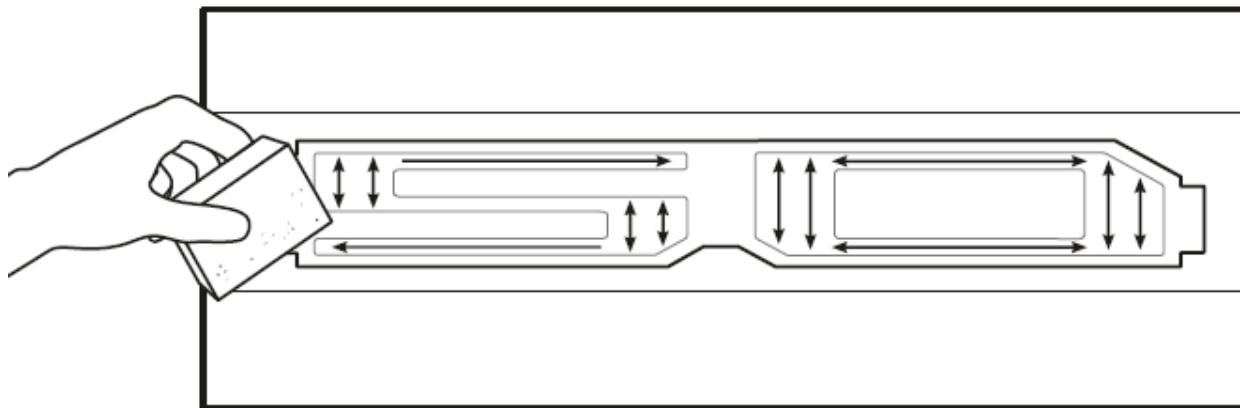

NO PART OF THIS DOCUMENT MAY BE REPRODUCED WITHOUT PRIOR AGREEMENT AND WRITTEN PERMISSION OF FORD PERFORMANCE PARTS © Ford Motor Company 2020

3.6 Slowly peel off the carrier of the “50” decal from right to left followed by the carrier of the “F-1” decal.

Properly dispose of decal carriers.

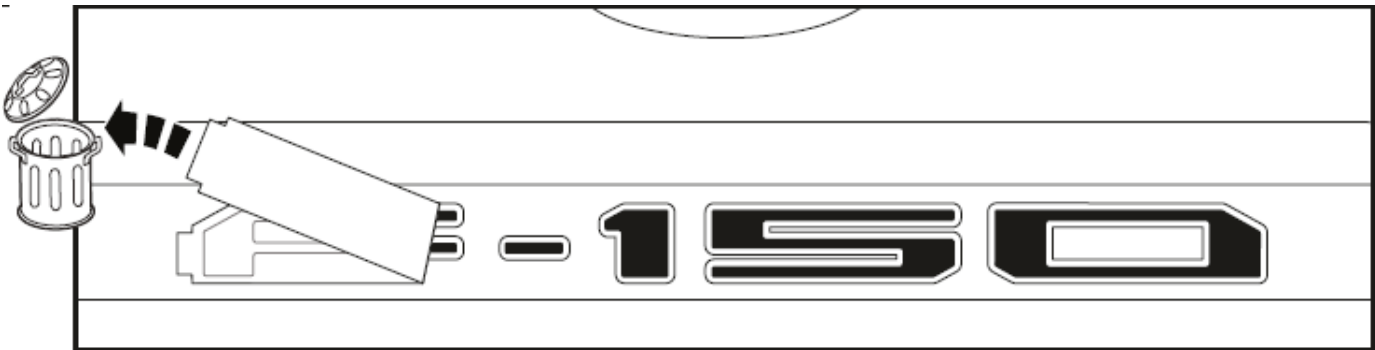
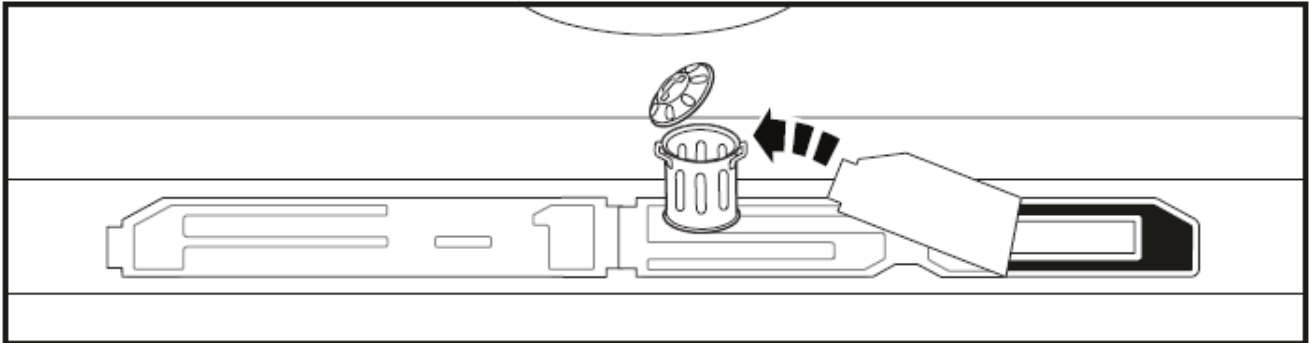



FORD **PERFORMANCE**

M-F150-FPS7 (Classic)
F-150 (4X4 Regular Cab & 4X2 Regular Cab)
FP700S Package

NO PART OF THIS DOCUMENT MAY BE REPRODUCED WITHOUT PRIOR AGREEMENT AND WRITTEN PERMISSION OF FORD PERFORMANCE PARTS © Ford Motor Company 2020

3a. Split Tailgate Lettering

Special Tool(s) / General Equipment

SOAP AND WATER SOLUTION



SQUEEGEE

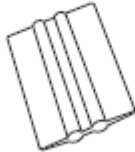

ALCOHOL WIPES



SOFT CLOTH



⚠ NOTE: The room temperature and surface temperature must be no lower than 68 degrees Fahrenheit (20° C) or higher than 90 degrees Fahrenheit (32° C) to ensure proper installation.

3.1 Clean surface using diluted rubbing alcohol (50/50) or an alcohol wipe to remove dirt and grease remove residue from area and allow area to dry thoroughly.

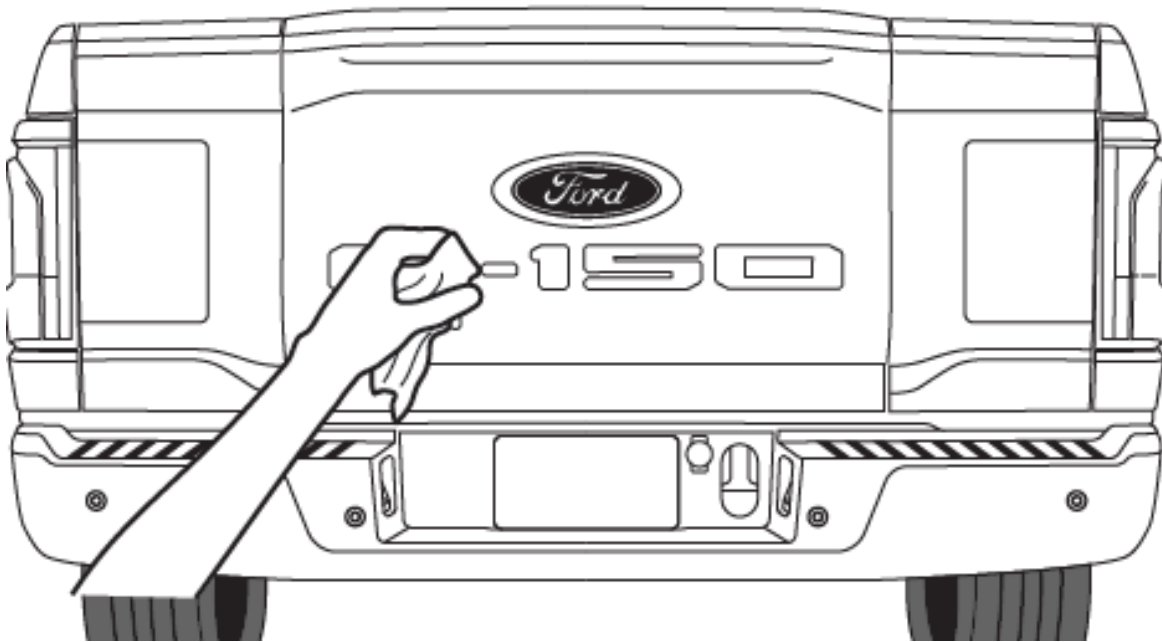

Ford Factory Shop Manual purchase options www.motorcraftservice.com



FORD **PERFORMANCE**

M-F150-FPS7 (Classic)
F-150 (4X4 Regular Cab & 4X2 Regular Cab)
FP700S Package

NO PART OF THIS DOCUMENT MAY BE REPRODUCED WITHOUT PRIOR AGREEMENT AND WRITTEN PERMISSION OF
FORD PERFORMANCE PARTS © Ford Motor Company 2020

3.2

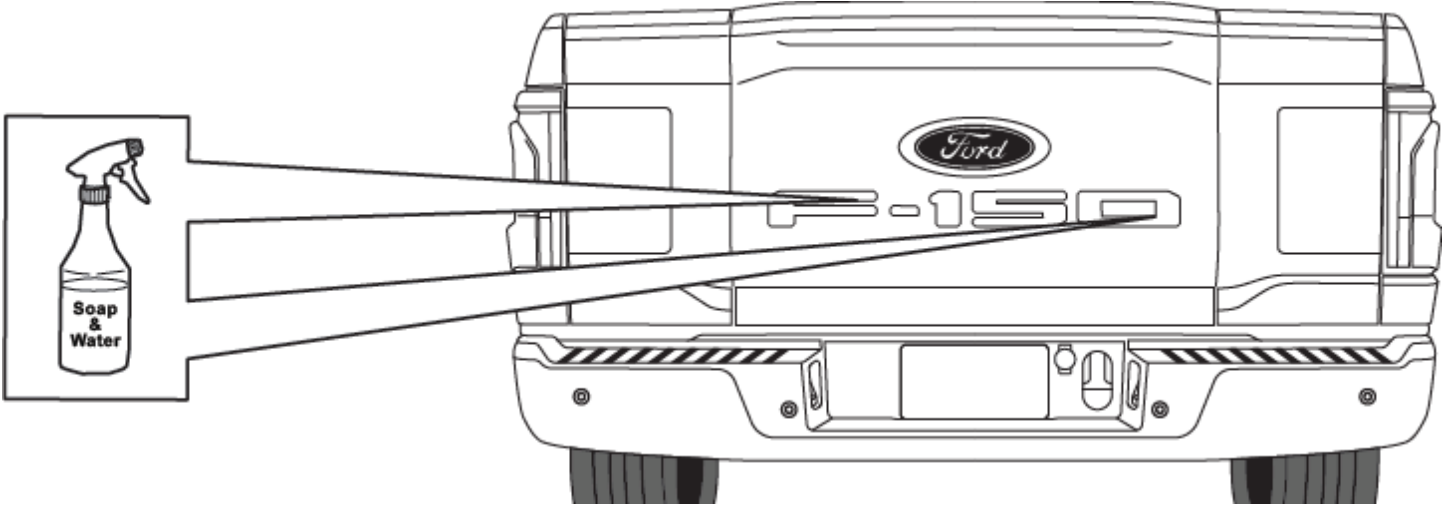

3.3

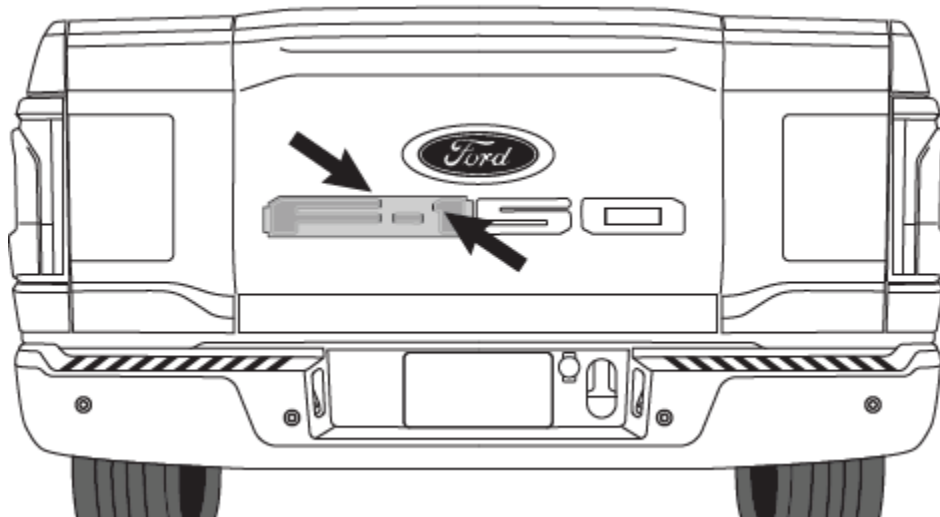

Ford Factory Shop Manual purchase options www.motorcraftservice.com



FORD PERFORMANCE

M-F150-FPS7 (Classic)
F-150 (4X4 Regular Cab & 4X2 Regular Cab)
FP700S Package

NO PART OF THIS DOCUMENT MAY BE REPRODUCED WITHOUT PRIOR AGREEMENT AND WRITTEN PERMISSION OF FORD PERFORMANCE PARTS © Ford Motor Company 2020

3.4

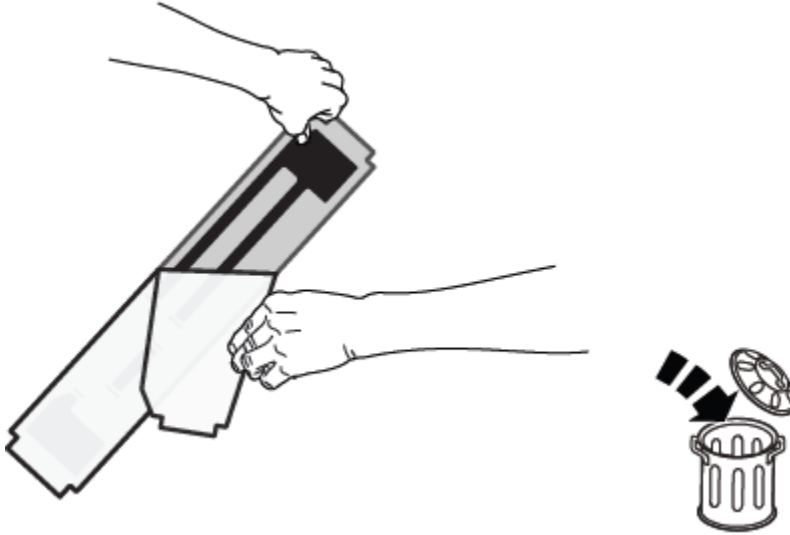

3.5

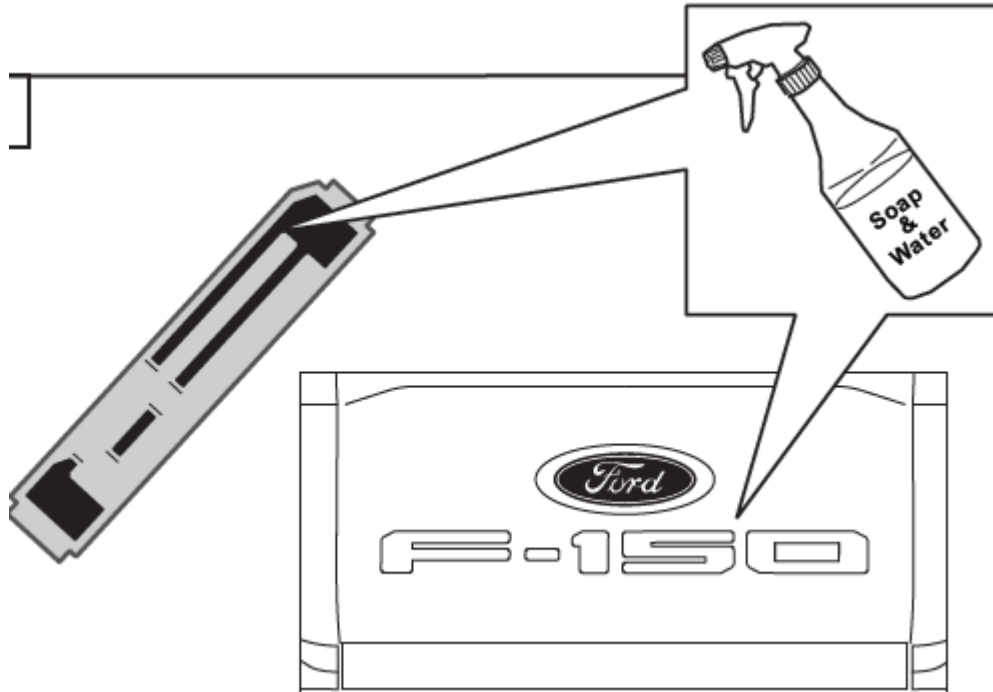

Ford Factory Shop Manual purchase options www.motorcraftservice.com



FORD PERFORMANCE

M-F150-FPS7 (Classic)
F-150 (4X4 Regular Cab & 4X2 Regular Cab)
FP700S Package

NO PART OF THIS DOCUMENT MAY BE REPRODUCED WITHOUT PRIOR AGREEMENT AND WRITTEN PERMISSION OF FORD PERFORMANCE PARTS © Ford Motor Company 2020

3.6

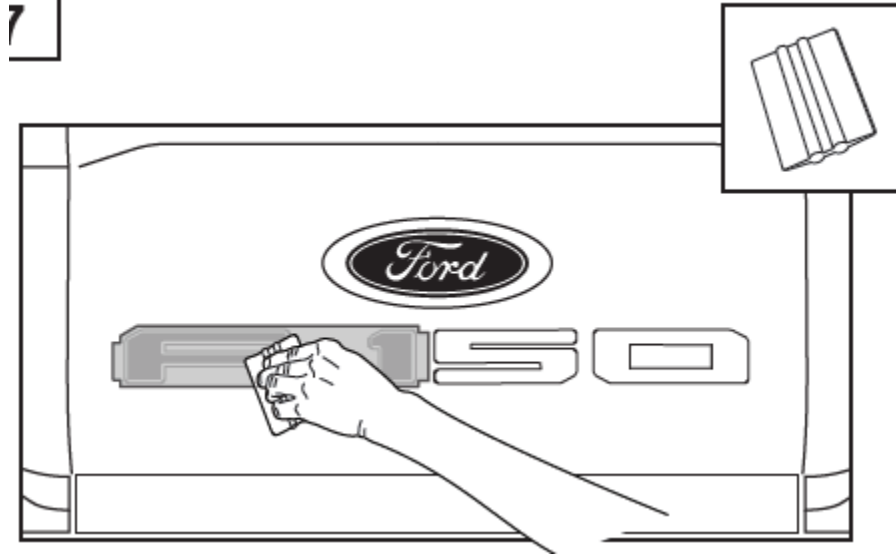

3.7

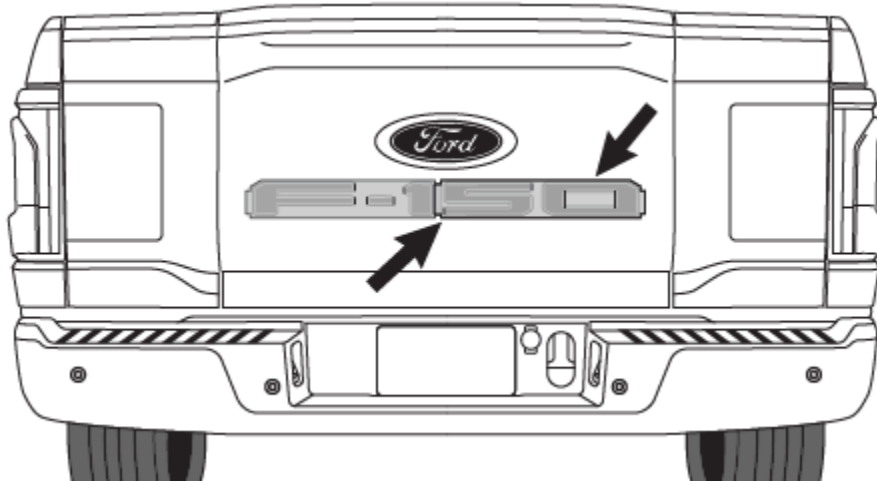

Ford Factory Shop Manual purchase options www.motorcraftservice.com

NO PART OF THIS DOCUMENT MAY BE REPRODUCED WITHOUT PRIOR AGREEMENT AND WRITTEN PERMISSION OF FORD PERFORMANCE PARTS © Ford Motor Company 2020

3.8

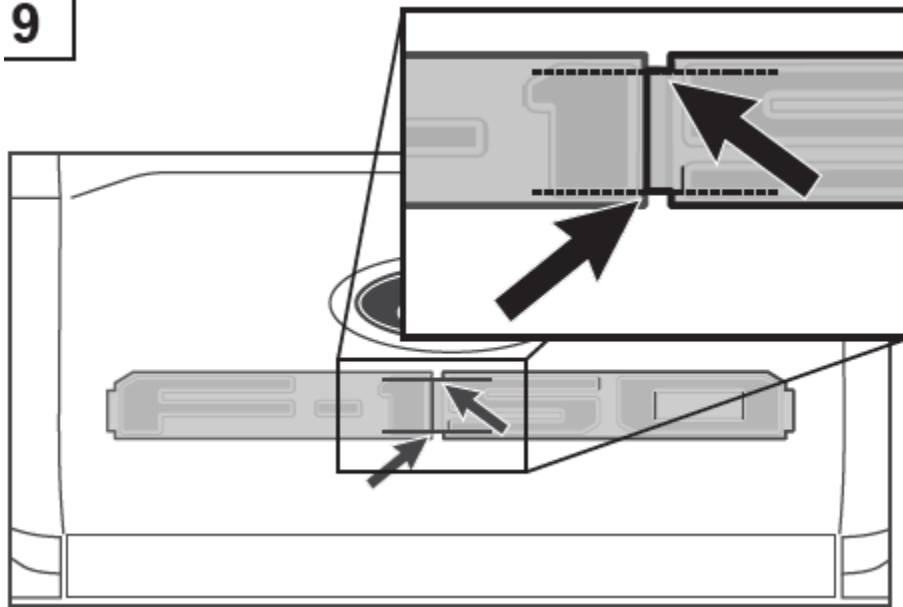

3.9

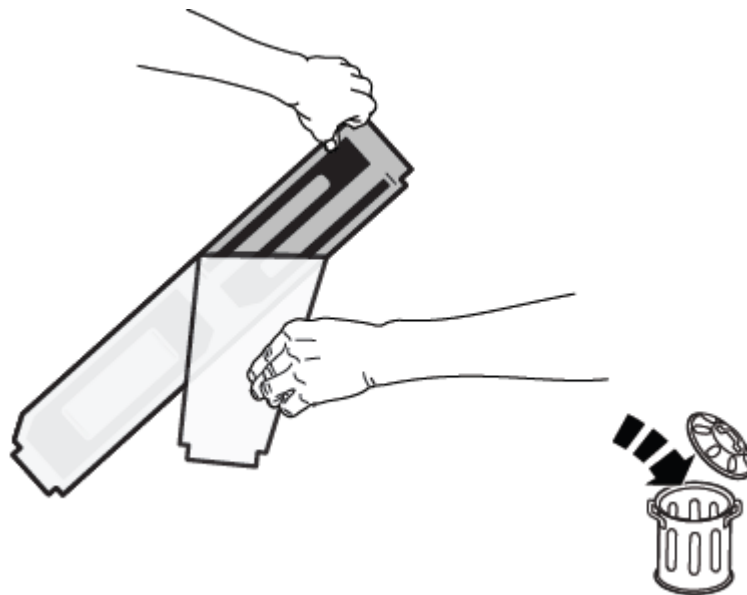

Ford Factory Shop Manual purchase options www.motorcraftservice.com



FORD PERFORMANCE

M-F150-FPS7 (Classic)
F-150 (4X4 Regular Cab & 4X2 Regular Cab)
FP700S Package

NO PART OF THIS DOCUMENT MAY BE REPRODUCED WITHOUT PRIOR AGREEMENT AND WRITTEN PERMISSION OF FORD PERFORMANCE PARTS © Ford Motor Company 2020

3.10

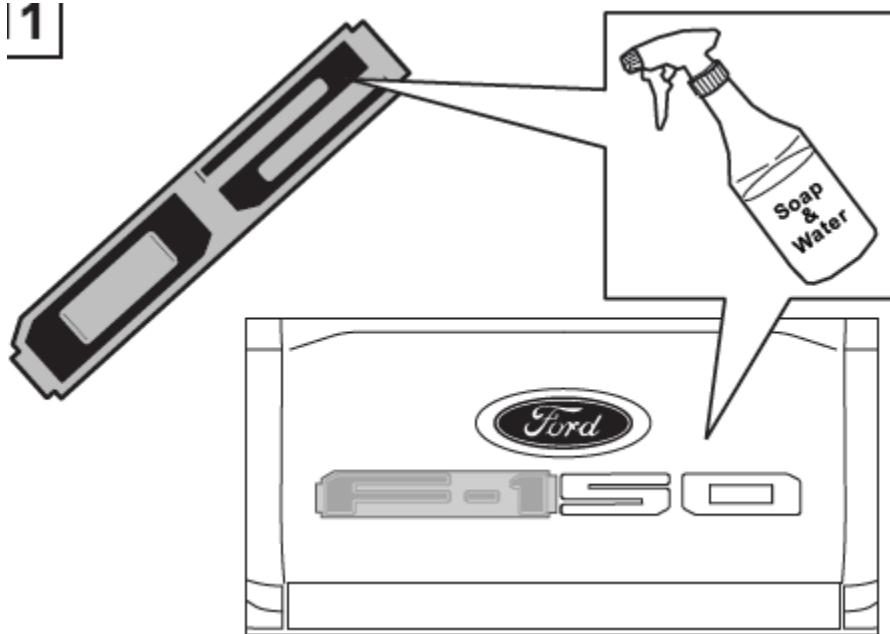

3.11

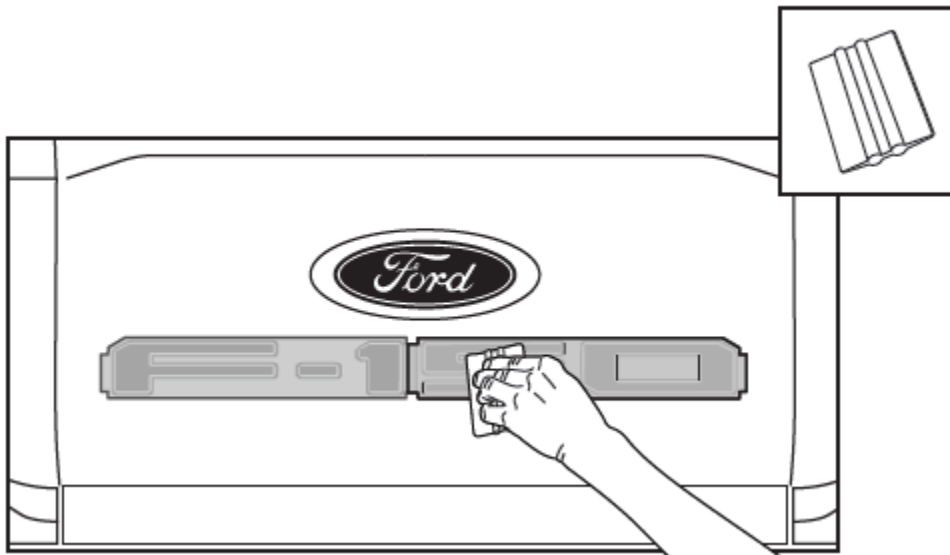

Ford Factory Shop Manual purchase options www.motorcraftservice.com



FORD **PERFORMANCE**

M-F150-FPS7 (Classic)
F-150 (4X4 Regular Cab & 4X2 Regular Cab)
FP700S Package

NO PART OF THIS DOCUMENT MAY BE REPRODUCED WITHOUT PRIOR AGREEMENT AND WRITTEN PERMISSION OF
FORD PERFORMANCE PARTS © Ford Motor Company 2020

3.12

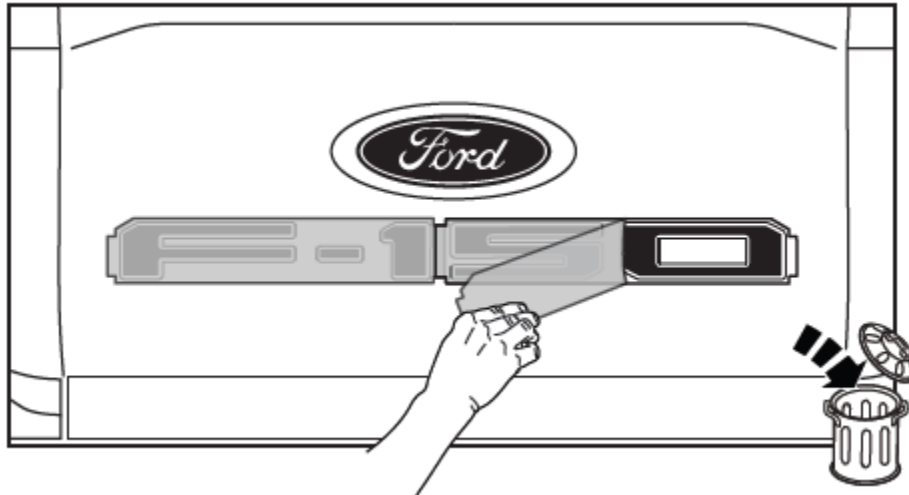

Ford Factory Shop Manual purchase options www.motorcraftservice.com



FORD PERFORMANCE

M-F150-FPS7 (Classic)
F-150 (4X4 Regular Cab & 4X2 Regular Cab)
FP700S Package

NO PART OF THIS DOCUMENT MAY BE REPRODUCED WITHOUT PRIOR AGREEMENT AND WRITTEN PERMISSION OF FORD PERFORMANCE PARTS © Ford Motor Company 2020

4. Bodyside Graphics

Special Tool(s) / General Equipment

SOAP AND WATER SOLUTION



SQUEEGEE

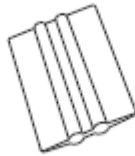

KNIFE



ALCOHOL WIPES



SOFT CLOTH



⚠ NOTE: The room temperature and surface temperature must be no lower than 68 degrees Fahrenheit (20° C) or higher than 90 degrees Fahrenheit (32° C) to ensure proper installation.

- 4.1 Clean surface with naphtha base cleaner to remove dirt and grease. Remove residue from area and allow area to dry thoroughly.

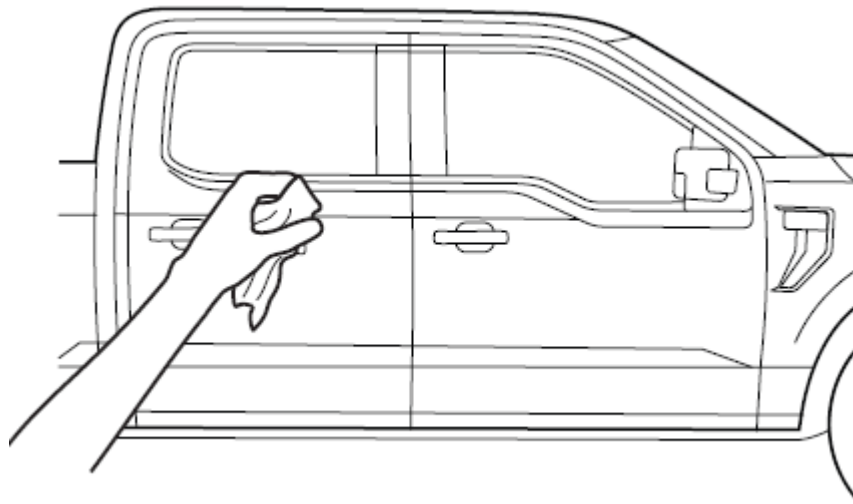

Ford Factory Shop Manual purchase options www.motorcraftservice.com



FORD PERFORMANCE

M-F150-FPS7 (Classic)
F-150 (4X4 Regular Cab & 4X2 Regular Cab)
FP700S Package

NO PART OF THIS DOCUMENT MAY BE REPRODUCED WITHOUT PRIOR AGREEMENT AND WRITTEN PERMISSION OF FORD PERFORMANCE PARTS © Ford Motor Company 2020

4.8 REGULAR CAB

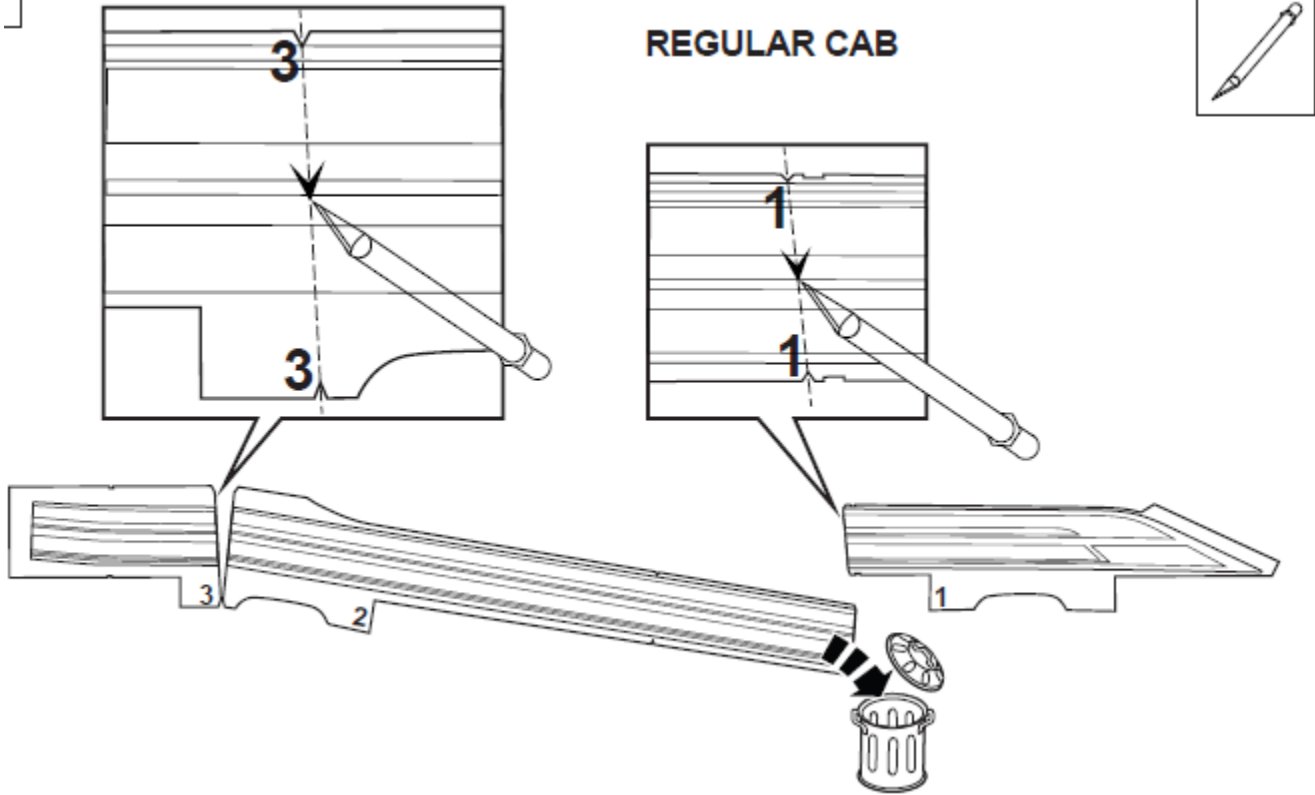

4.9

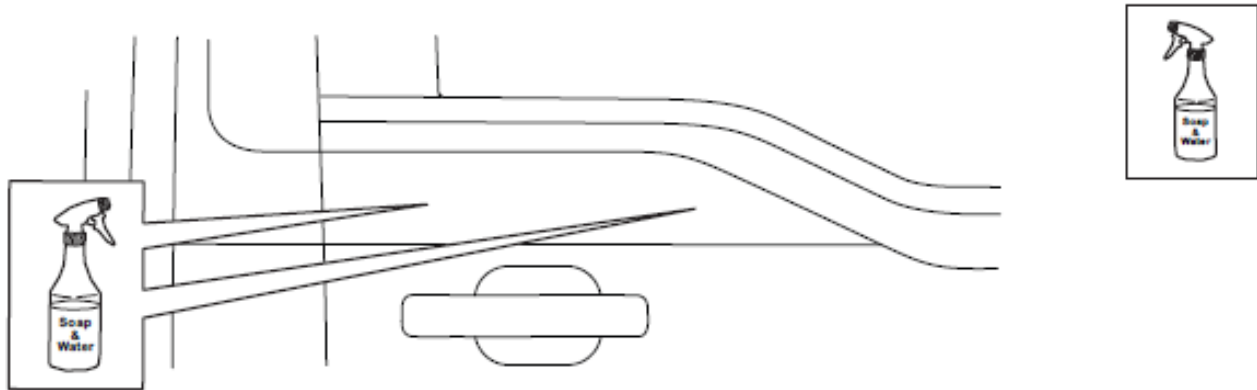

4.10

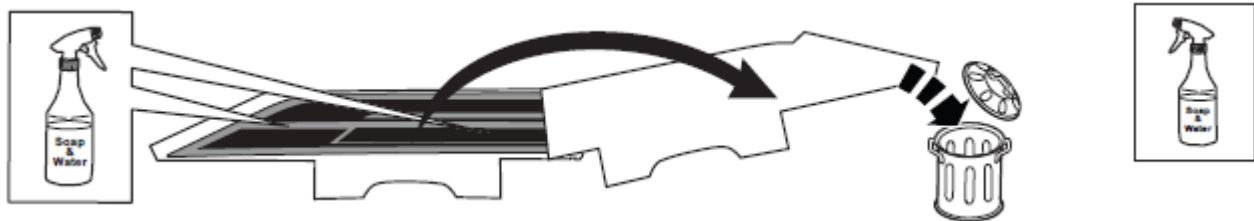

Ford Factory Shop Manual purchase options www.motorcraftservice.com



FORD PERFORMANCE

M-F150-FPS7 (Classic)
F-150 (4X4 Regular Cab & 4X2 Regular Cab)
FP700S Package

NO PART OF THIS DOCUMENT MAY BE REPRODUCED WITHOUT PRIOR AGREEMENT AND WRITTEN PERMISSION OF FORD PERFORMANCE PARTS © Ford Motor Company 2020

4.11

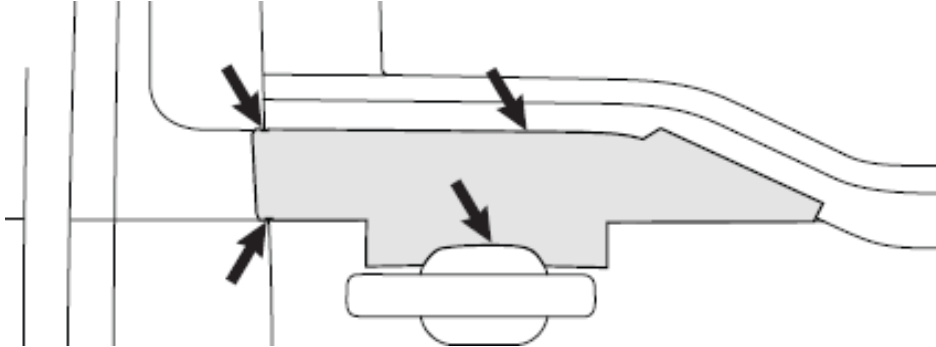

4.12

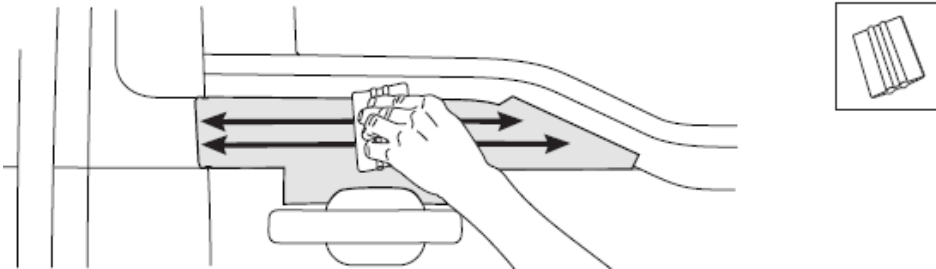

4.13

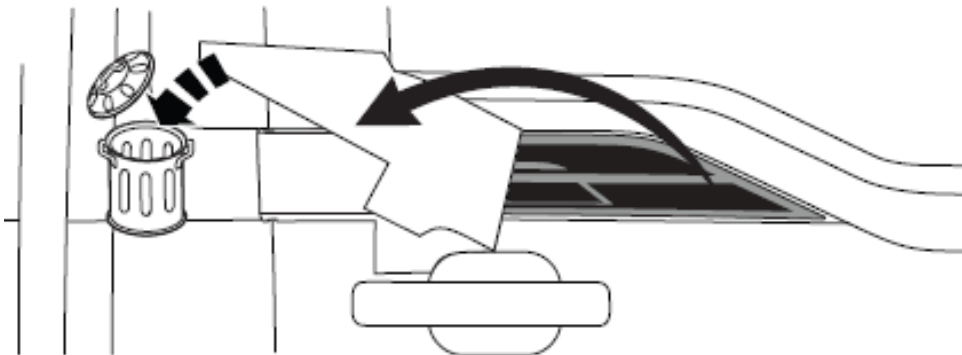

Ford Factory Shop Manual purchase options www.motorcraftservice.com



FORD PERFORMANCE

M-F150-FPS7 (Classic)
F-150 (4X4 Regular Cab & 4X2 Regular Cab)
FP700S Package

NO PART OF THIS DOCUMENT MAY BE REPRODUCED WITHOUT PRIOR AGREEMENT AND WRITTEN PERMISSION OF FORD PERFORMANCE PARTS © Ford Motor Company 2020

4.14

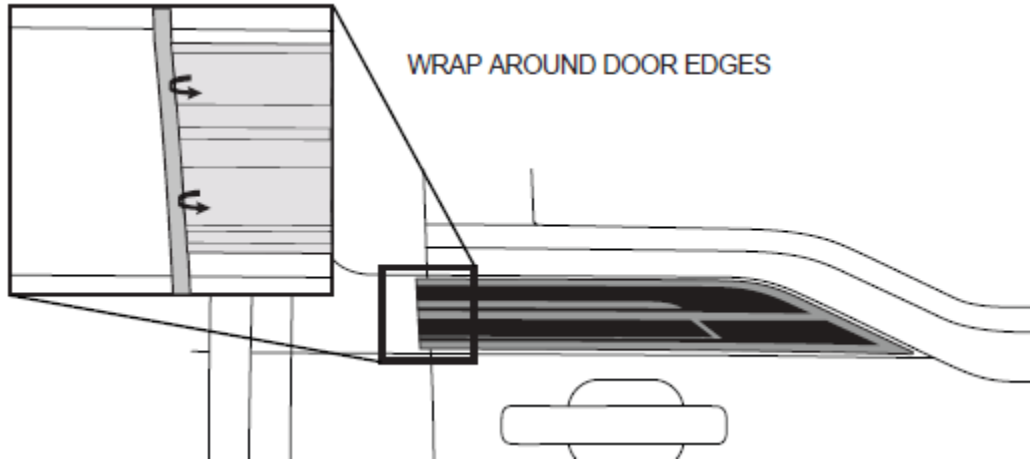

4.15

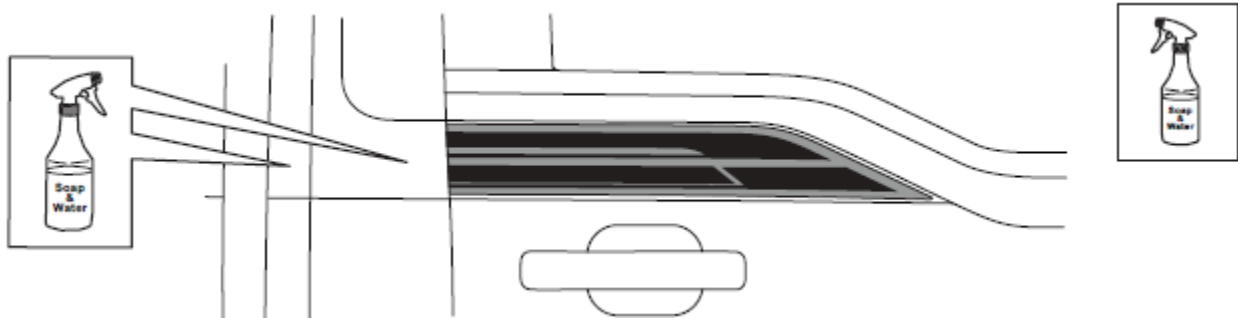

4.16

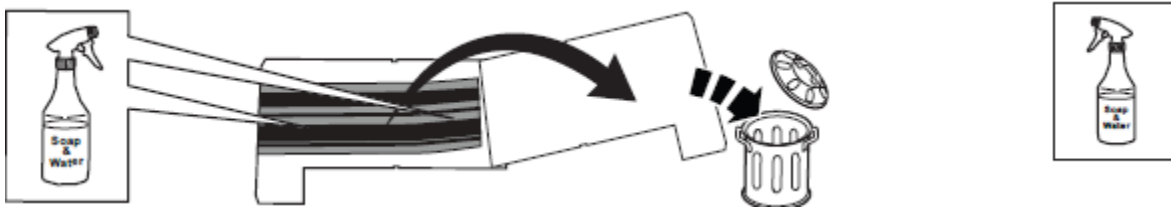

4.17

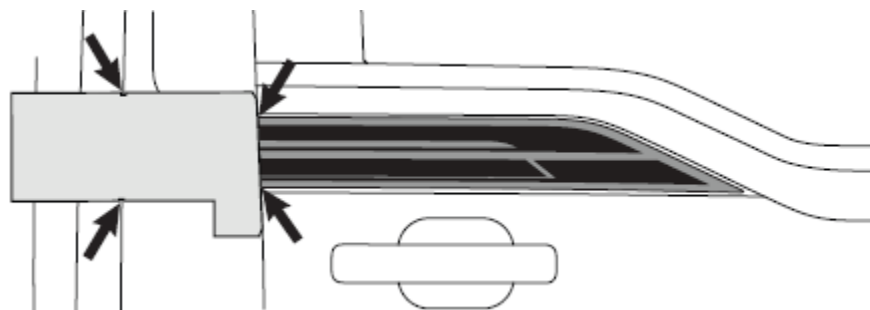

Ford Factory Shop Manual purchase options www.motorcraftservice.com



FORD PERFORMANCE

M-F150-FPS7 (Classic)
F-150 (4X4 Regular Cab & 4X2 Regular Cab)
FP700S Package

NO PART OF THIS DOCUMENT MAY BE REPRODUCED WITHOUT PRIOR AGREEMENT AND WRITTEN PERMISSION OF FORD PERFORMANCE PARTS © Ford Motor Company 2020

4.18

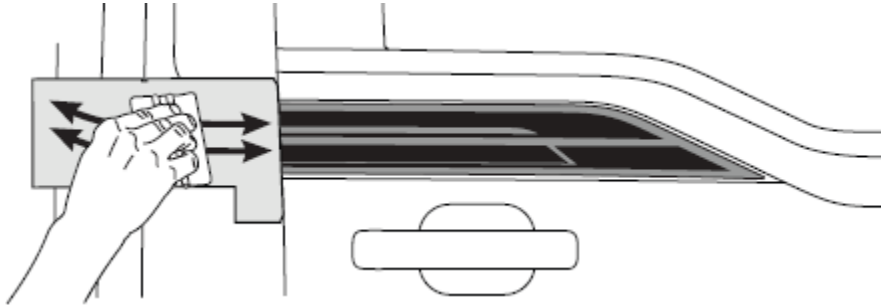

4.19

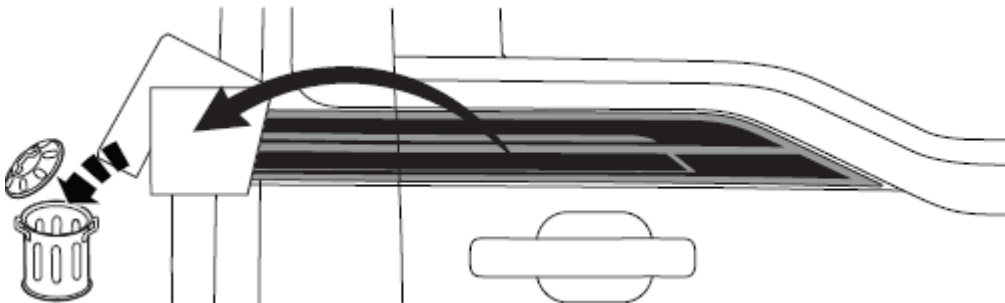

4.20

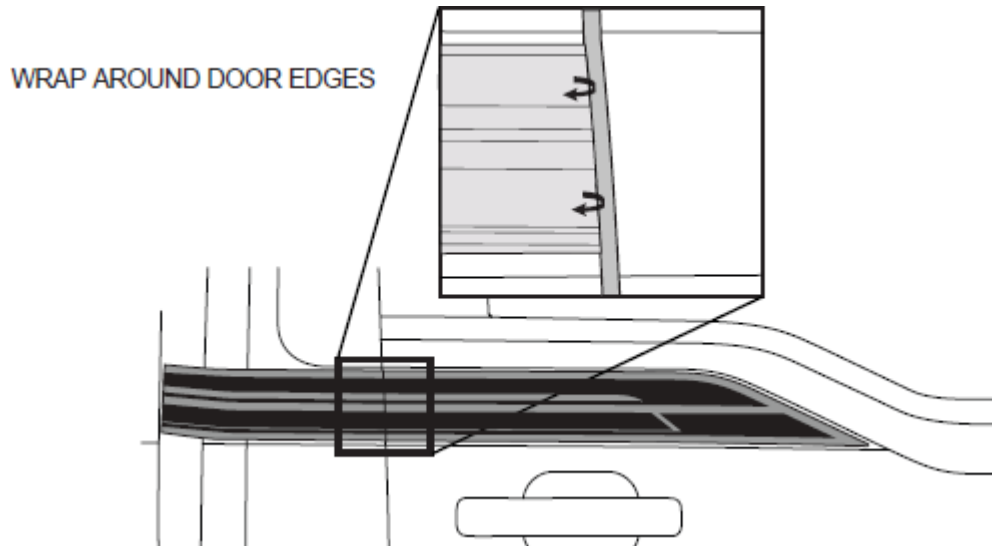

Ford Factory Shop Manual purchase options www.motorcraftservice.com



FORD PERFORMANCE

M-F150-FPS7 (Classic)
F-150 (4X4 Regular Cab & 4X2 Regular Cab)
FP700S Package

NO PART OF THIS DOCUMENT MAY BE REPRODUCED WITHOUT PRIOR AGREEMENT AND WRITTEN PERMISSION OF FORD PERFORMANCE PARTS © Ford Motor Company 2020

4.21

FOR 6.5 FOOT BOX

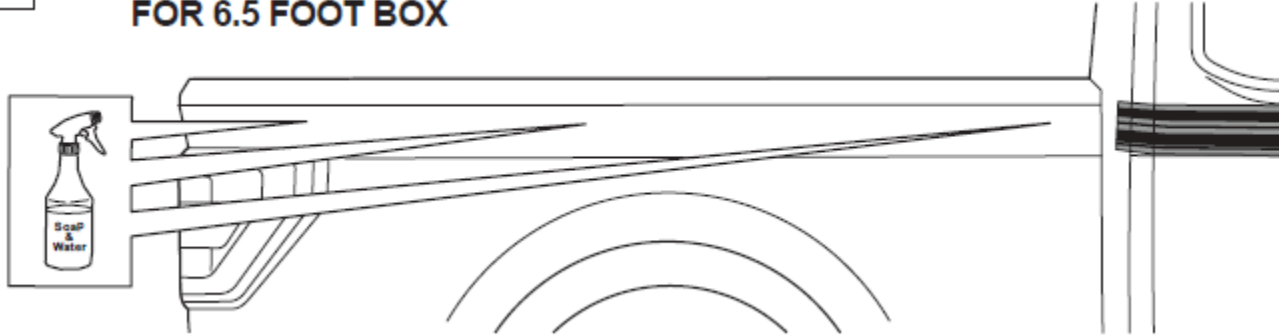

4.22



4.23



4.24

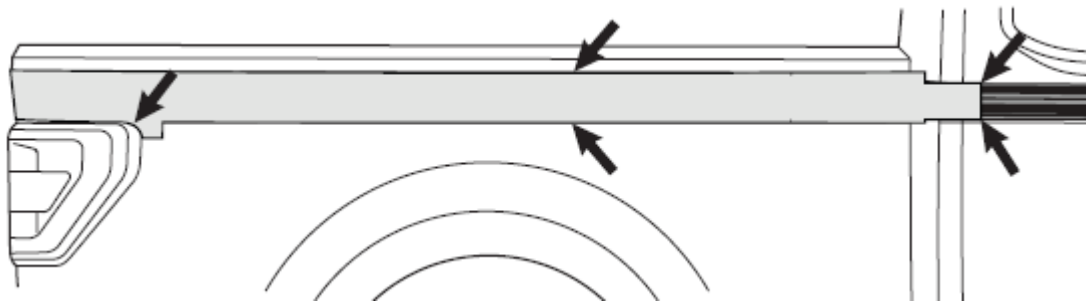

4.25

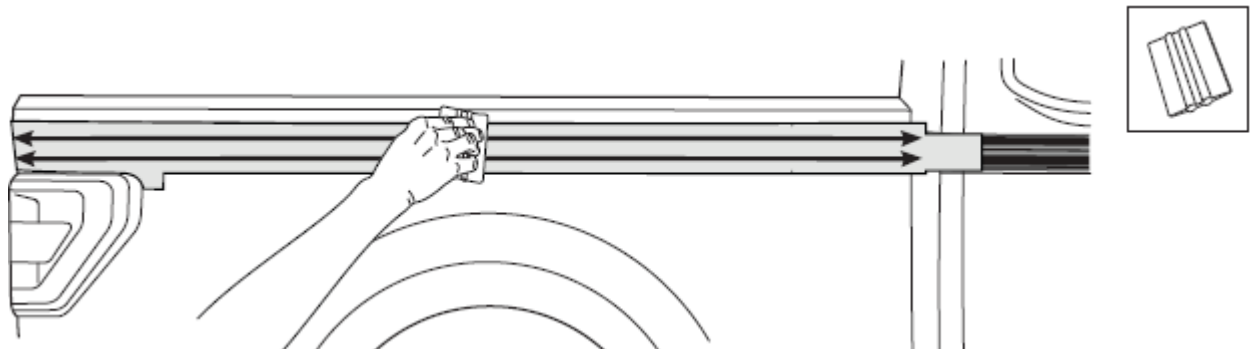

Ford Factory Shop Manual purchase options www.motorcraftservice.com



FORD **PERFORMANCE**

M-F150-FPS7 (Classic)
F-150 (4X4 Regular Cab & 4X2 Regular Cab)
FP700S Package

NO PART OF THIS DOCUMENT MAY BE REPRODUCED WITHOUT PRIOR AGREEMENT AND WRITTEN PERMISSION OF
FORD PERFORMANCE PARTS © Ford Motor Company 2020

4.26

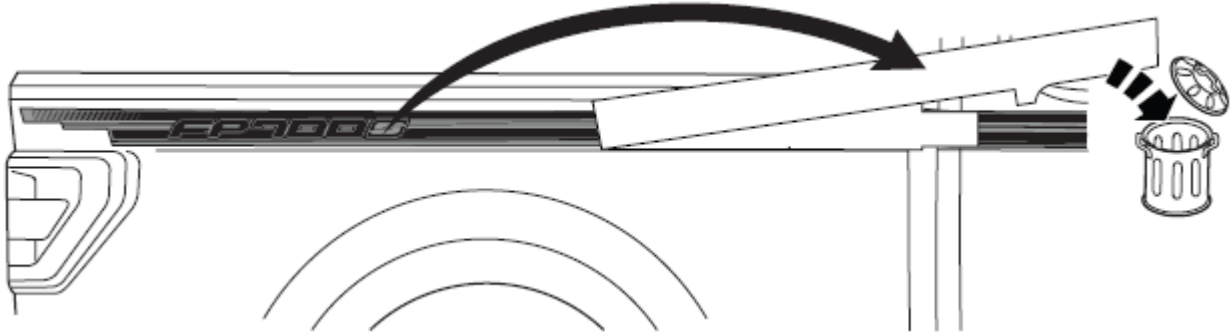

4.27

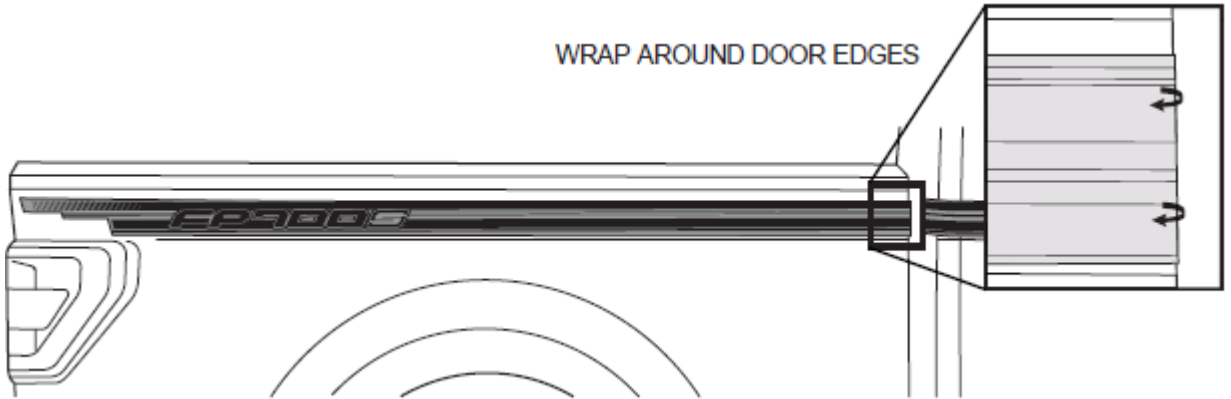

Ford Factory Shop Manual purchase options www.motorcraftservice.com



FORD PERFORMANCE

M-F150-FPS7 (Classic)
F-150 (4X4 Regular Cab & 4X2 Regular Cab)
FP700S Package

NO PART OF THIS DOCUMENT MAY BE REPRODUCED WITHOUT PRIOR AGREEMENT AND WRITTEN PERMISSION OF FORD PERFORMANCE PARTS © Ford Motor Company 2020

4.28 5.5 FOOT BOX

FOR 5.5 FOOT BOX

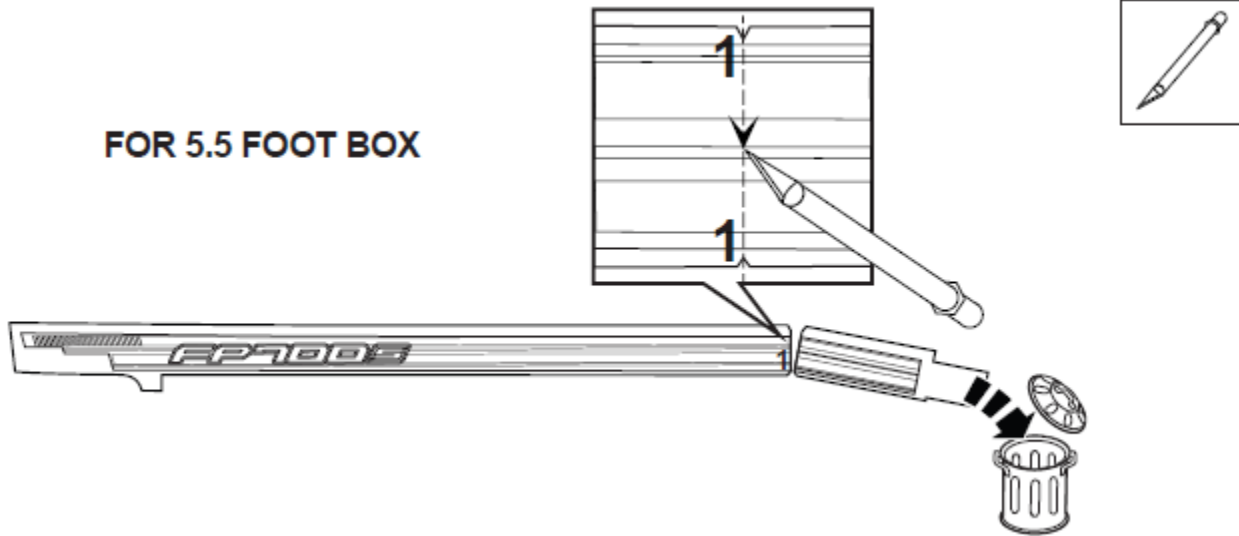

4.29

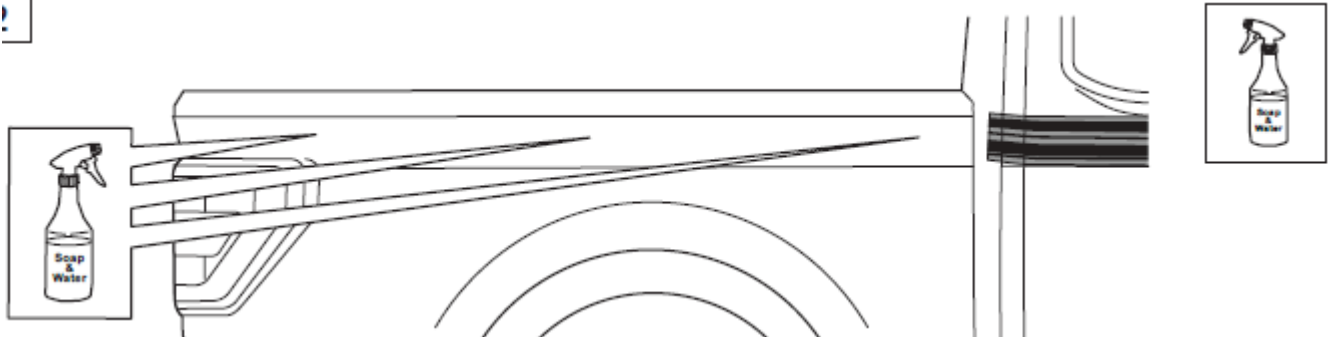

4.30

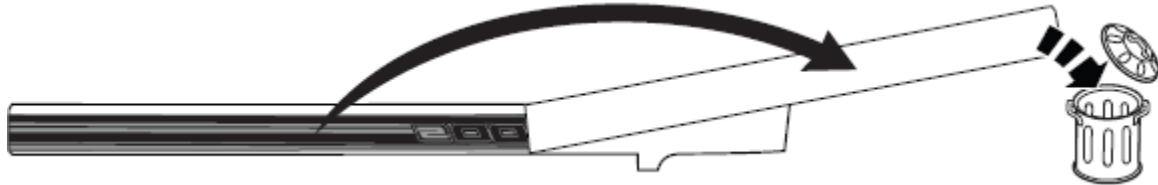

4.31

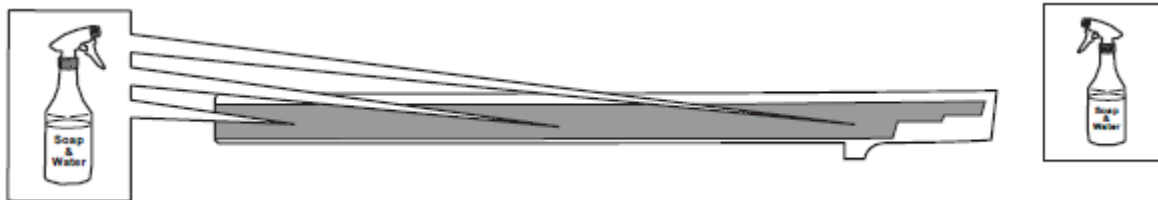

Ford Factory Shop Manual purchase options www.motorcraftservice.com



FORD PERFORMANCE

M-F150-FPS7 (Classic)
F-150 (4X4 Regular Cab & 4X2 Regular Cab)
FP700S Package

NO PART OF THIS DOCUMENT MAY BE REPRODUCED WITHOUT PRIOR AGREEMENT AND WRITTEN PERMISSION OF FORD PERFORMANCE PARTS © Ford Motor Company 2020

4.32

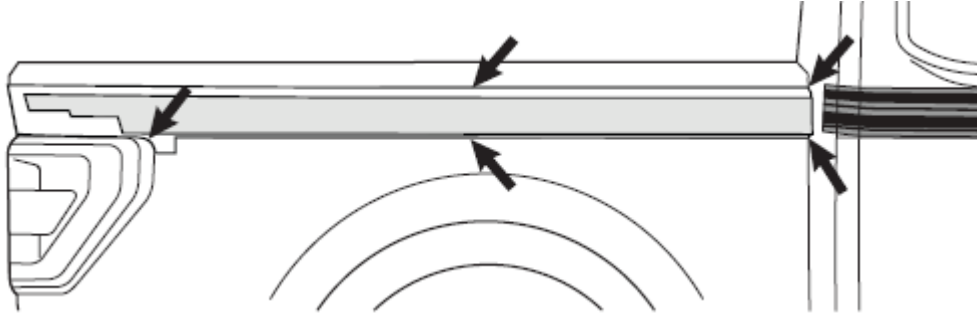

4.33

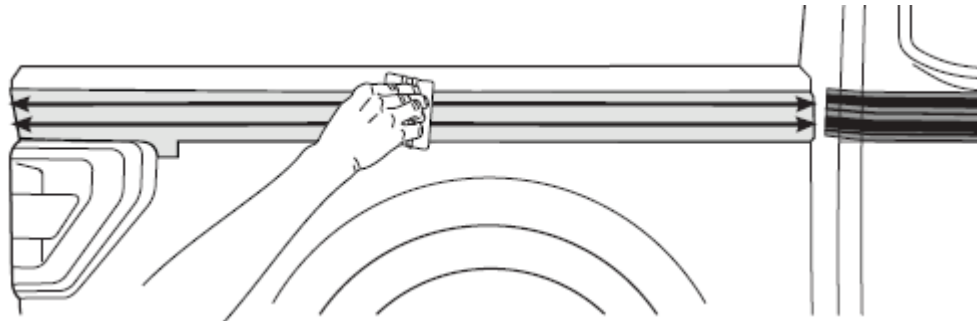

4.34

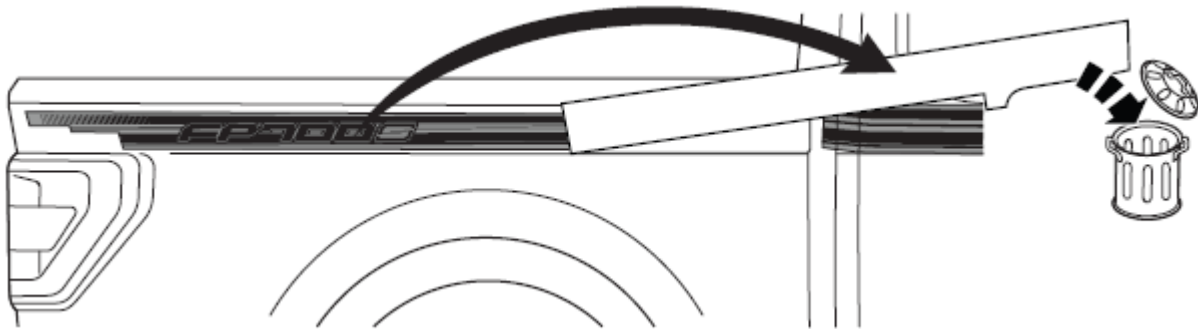

4.35



Ford Factory Shop Manual purchase options www.motorcraftservice.com



FORD PERFORMANCE

M-F150-FPS7 (Classic)
F-150 (4X4 Regular Cab & 4X2 Regular Cab)
FP700S Package

NO PART OF THIS DOCUMENT MAY BE REPRODUCED WITHOUT PRIOR AGREEMENT AND WRITTEN PERMISSION OF FORD PERFORMANCE PARTS © Ford Motor Company 2020

5. Hood Graphics

Special Tool(s) / General Equipment

SOAP AND WATER SOLUTION



SQUEEGEE

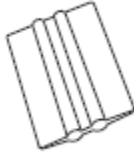

ALCOHOL WIPES



SOFT CLOTH



1

NOTE: THE ROOM TEMPERATURE AND SURFACE TEMPERATURE MUST BE NO LOWER THAN 88 DEGREES FAHRENHEIT (20° C) OR HIGHER THAN 90 DEGREES FAHRENHEIT (32° C) TO ENSURE PROPER INSTALLATION.



2

NOTE: CLEAN SURFACE WITH NAPHTHA BASE CLEANER TO REMOVE DIRT AND GREASE. REMOVE RESIDUE FROM AREA AND ALLOW AREA TO DRY THOROUGHLY.

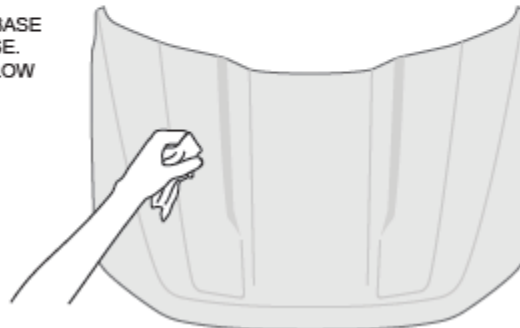

Ford Factory Shop Manual purchase options www.motorcraftservice.com



FORD PERFORMANCE

M-F150-FPS7 (Classic)
F-150 (4X4 Regular Cab & 4X2 Regular Cab)
FP700S Package

NO PART OF THIS DOCUMENT MAY BE REPRODUCED WITHOUT PRIOR AGREEMENT AND WRITTEN PERMISSION OF FORD PERFORMANCE PARTS © Ford Motor Company 2020

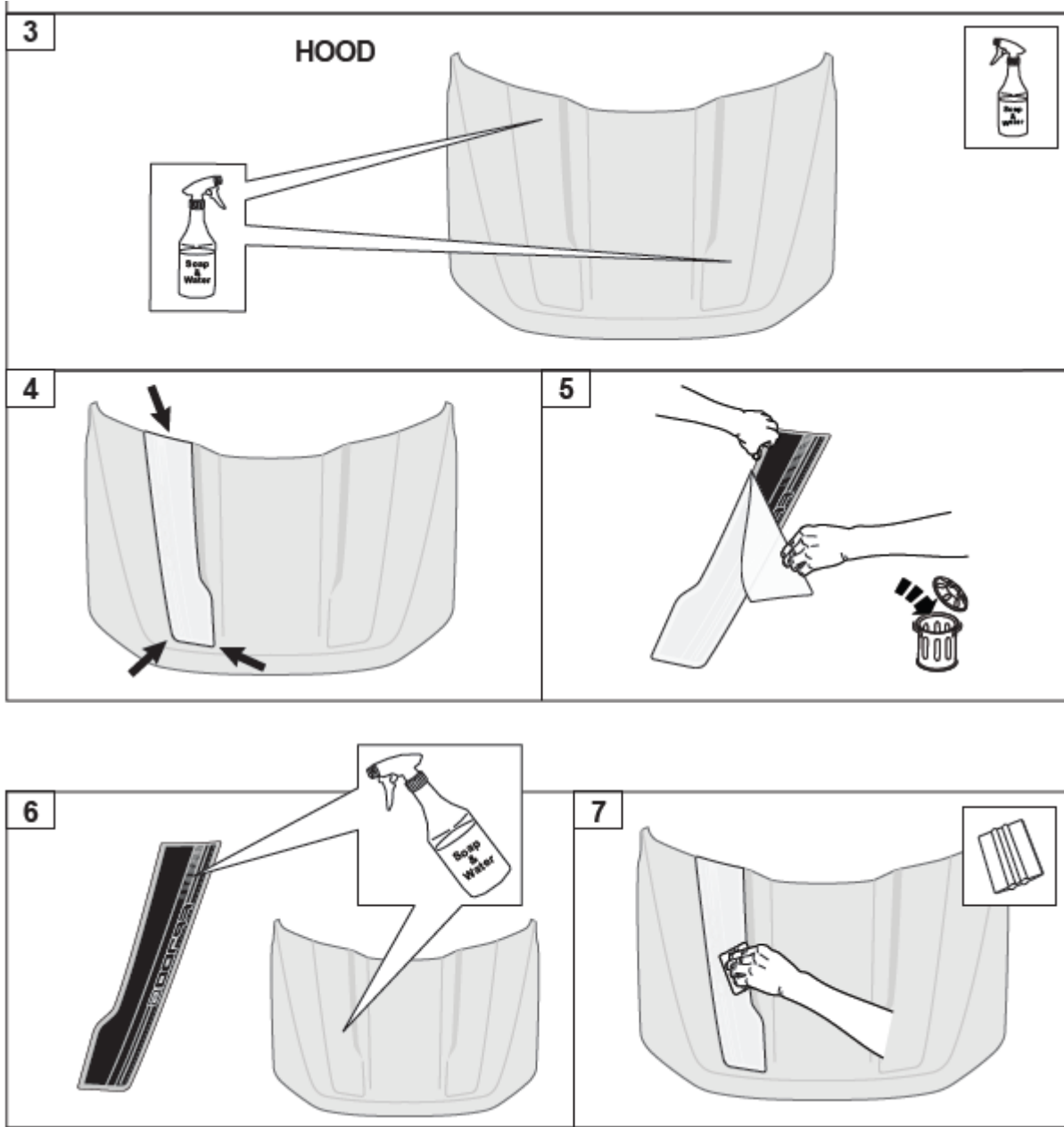

Ford Factory Shop Manual purchase options www.motorcraftservice.com



FORD PERFORMANCE

M-F150-FPS7 (Classic)
F-150 (4X4 Regular Cab & 4X2 Regular Cab)
FP700S Package

NO PART OF THIS DOCUMENT MAY BE REPRODUCED WITHOUT PRIOR AGREEMENT AND WRITTEN PERMISSION OF FORD PERFORMANCE PARTS © Ford Motor Company 2020

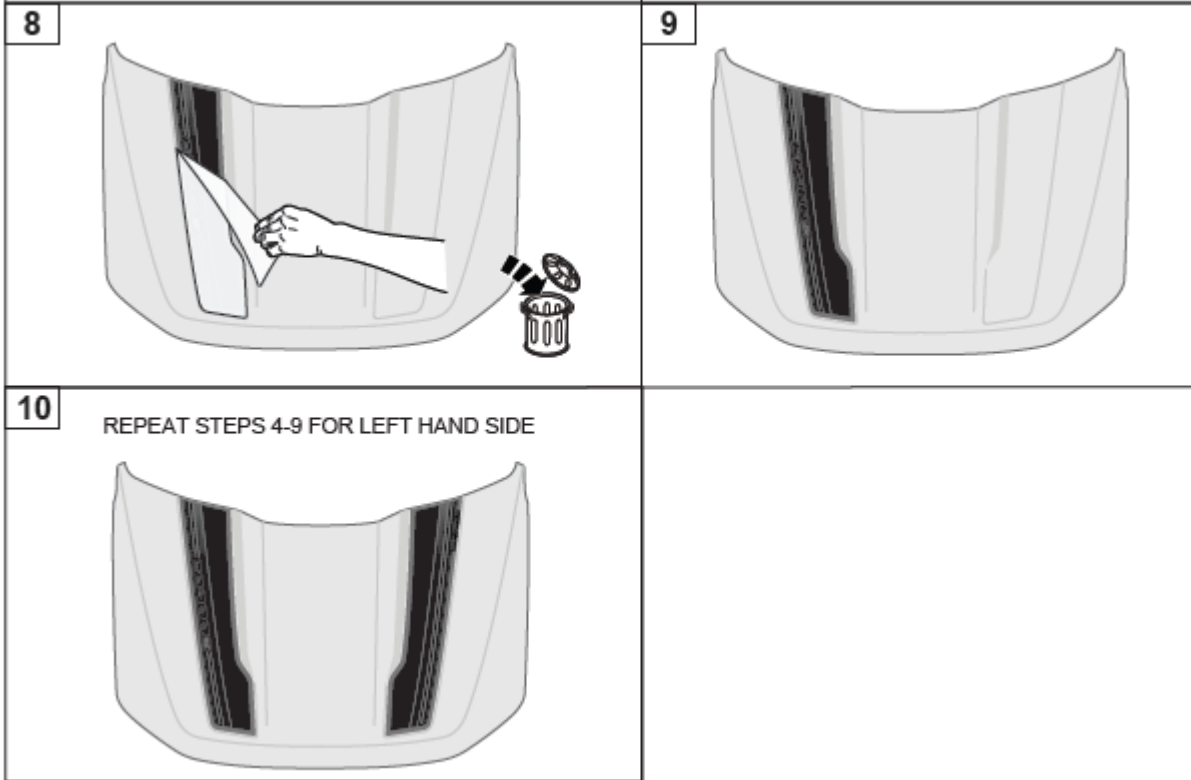

Ford Factory Shop Manual purchase options www.motorcraftservice.com

NO PART OF THIS DOCUMENT MAY BE REPRODUCED WITHOUT PRIOR AGREEMENT AND WRITTEN PERMISSION OF FORD PERFORMANCE PARTS © Ford Motor Company 2020

6. Ford Performance Fender Vents

Special Tool(s) / General Equipment

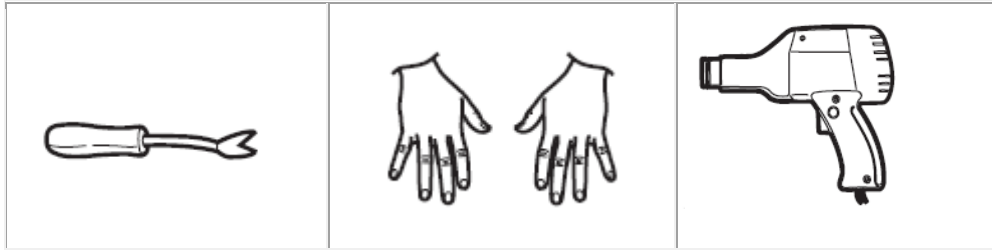

Removal

NOTE: Removal steps in this procedure may contain installation details.

 Extreme cold weather will cause breakage. A hair dryer can be used to localize warmth before flexing release tabs.

- 3.1 Using a non-marring plastic trim removal tool, start along the top of the fender vent and work your way down the sides to gently pry up and release the vent from the clips on the backside.



Ford Factory Shop Manual purchase options www.motorcraftservice.com



FORD PERFORMANCE

M-F150-FPS7 (Classic)
F-150 (4X4 Regular Cab & 4X2 Regular Cab)
FP700S Package

NO PART OF THIS DOCUMENT MAY BE REPRODUCED WITHOUT PRIOR AGREEMENT AND WRITTEN PERMISSION OF
FORD PERFORMANCE PARTS © Ford Motor Company 2020

3.2 If the clips remained in the slots on the fender, remove old clips before installing new fender vent.

Installation

3.3 To install, line up the clips on the backside of the fender vent with the slots on the fender. Apply pressure evenly to snap clips into place.



Ford Factory Shop Manual purchase options www.motorcraftservice.com

NO PART OF THIS DOCUMENT MAY BE REPRODUCED WITHOUT PRIOR AGREEMENT AND WRITTEN PERMISSION OF FORD PERFORMANCE PARTS © Ford Motor Company 2020

7. Rocker Panel Aero Shield Kit

Special Tool(s) / General Equipment

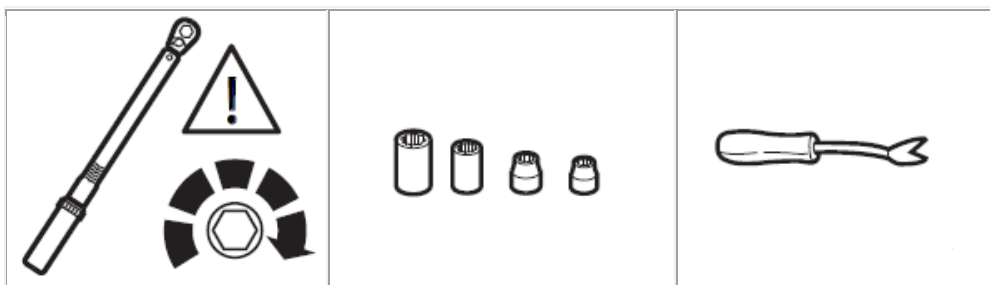

3.4 Remove the 3 bolts.

Right side shown, Left side similar.



3.5 Pop out the retainer clips and remove the rocker panel aero piece.

Installation

5.3 To install, reverse the removal procedure.

Ford Factory Shop Manual purchase options www.motorcraftservice.com



FORD PERFORMANCE

M-F150-FPS7 (Classic)
F-150 (4X4 Regular Cab & 4X2 Regular Cab)
FP700S Package

NO PART OF THIS DOCUMENT MAY BE REPRODUCED WITHOUT PRIOR AGREEMENT AND WRITTEN PERMISSION OF FORD PERFORMANCE PARTS © Ford Motor Company 2020

8. Front Lip Splitter

Special Tool(s) / General Equipment



A	FRONT LIP SPOILER R1 PART / PARTE / PIÈCE #: VRL3Z-17626-A		1 PC
B	Adhesion promoter / Promotor de adhesión / Promoteur d'adhésion		1 PC
C	Polyurethane adhesive / Adhesivo de poliuretano / Scellant polyuréthane		1 PC
D	Push pin Würth / Grapas Würth / Agrafe sapin Würth #46		3 PCS

Ford Factory Shop Manual purchase options www.motorcraftservice.com



FORD PERFORMANCE

M-F150-FPS7 (Classic)
F-150 (4X4 Regular Cab & 4X2 Regular Cab)
FP700S Package

NO PART OF THIS DOCUMENT MAY BE REPRODUCED WITHOUT PRIOR AGREEMENT AND WRITTEN PERMISSION OF FORD PERFORMANCE PARTS © Ford Motor Company 2020

1 MARK THE VEHICLE WITH MASKING TAPE

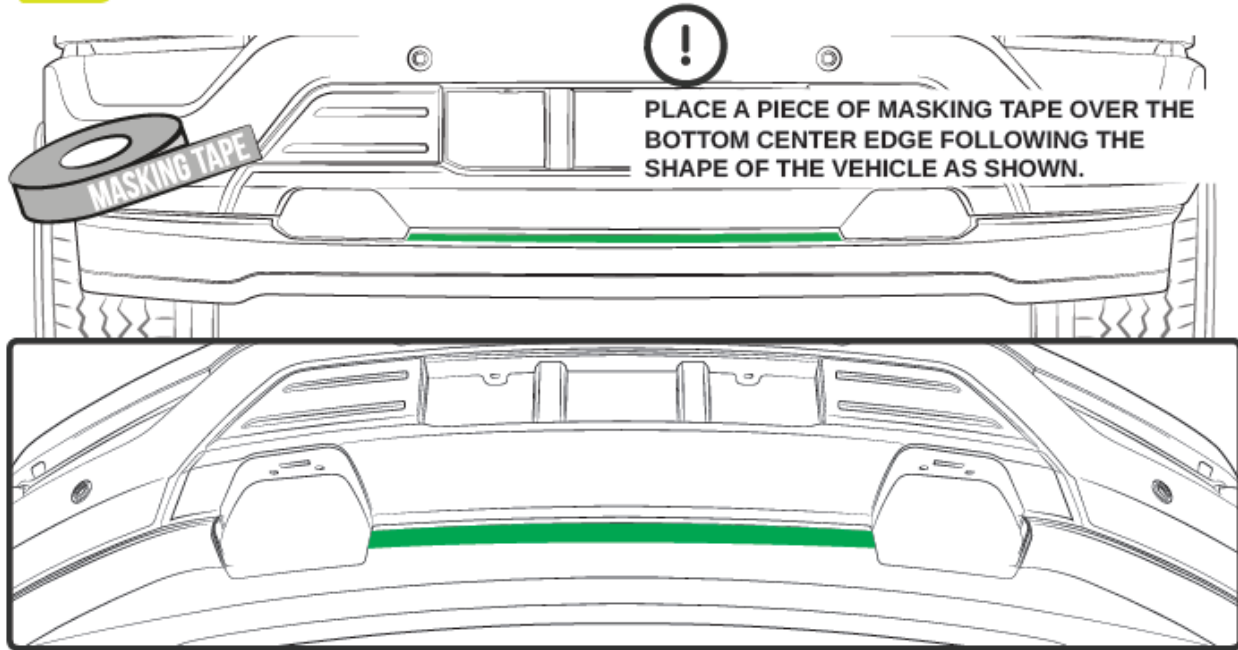

2 TEST FIT / PRE-INSTALE / TESTEZ L'AJUSTEMENT

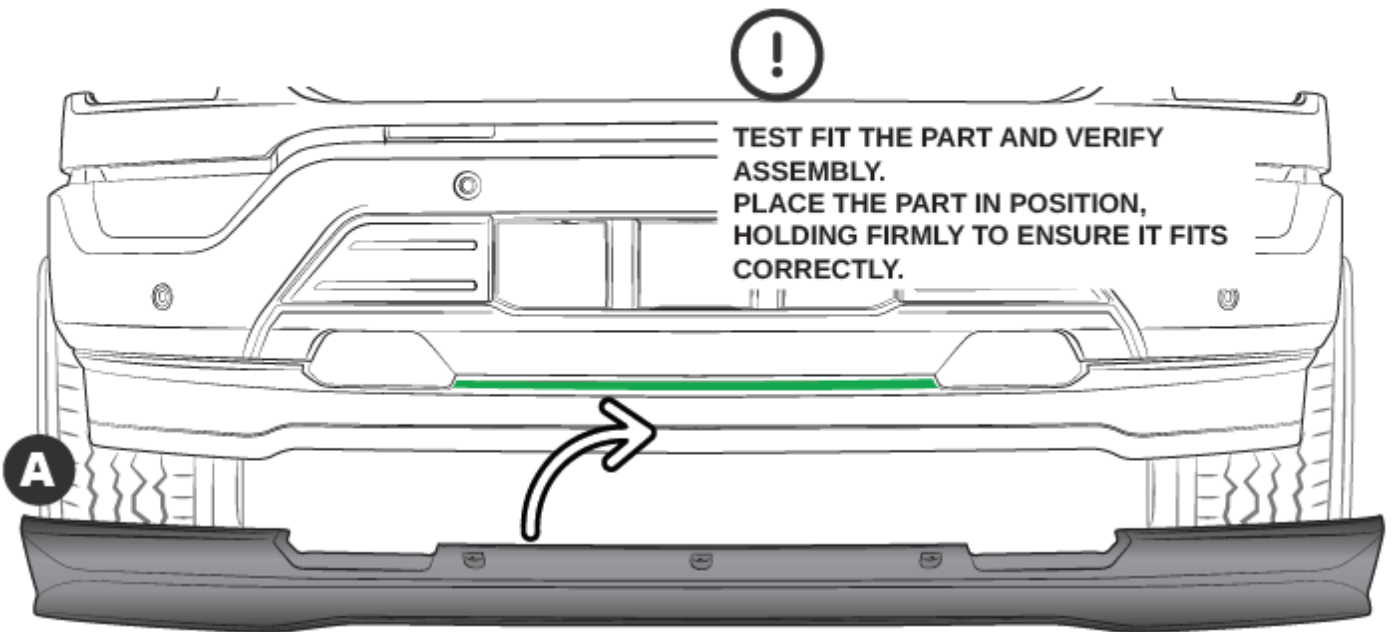

Ford Factory Shop Manual purchase options www.motorcraftservice.com



FORD PERFORMANCE

M-F150-FPS7 (Classic)
F-150 (4X4 Regular Cab & 4X2 Regular Cab)
FP700S Package

NO PART OF THIS DOCUMENT MAY BE REPRODUCED WITHOUT PRIOR AGREEMENT AND WRITTEN PERMISSION OF FORD PERFORMANCE PARTS © Ford Motor Company 2020

3 MARK / MARQUE / MARQUEZ



MARK AS SHOWN.

WITH THE HELP OF A PEN, MARK THE DRILL HOLES.

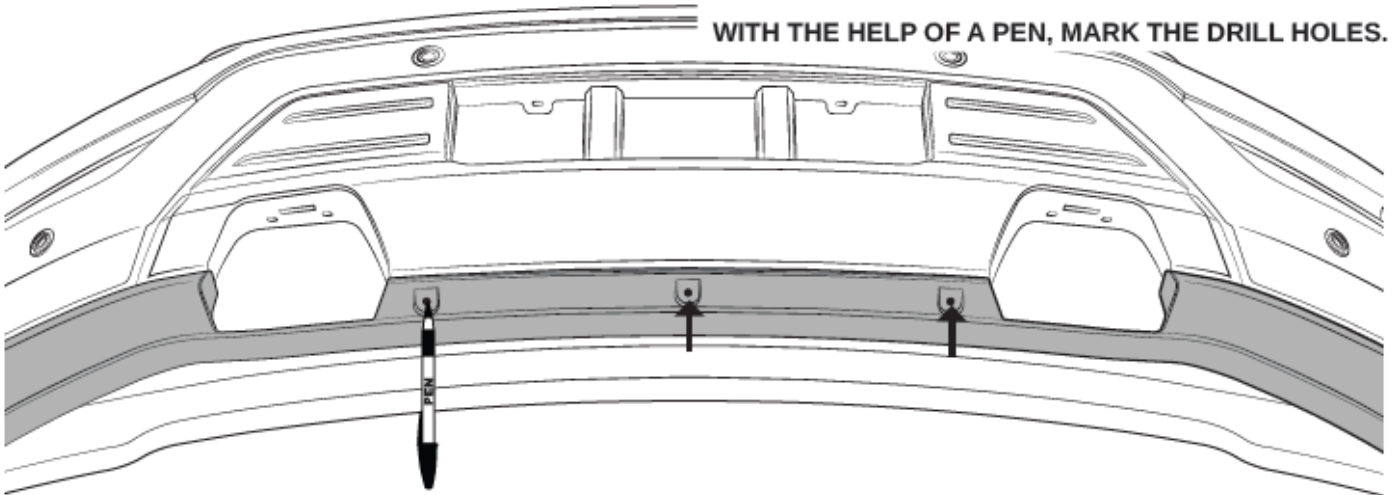

4 REMOVE THE PART / RETIRE LA PIEZA / RETIREZ LA PIÈCE



REMOVE AND SAFE THE PART.

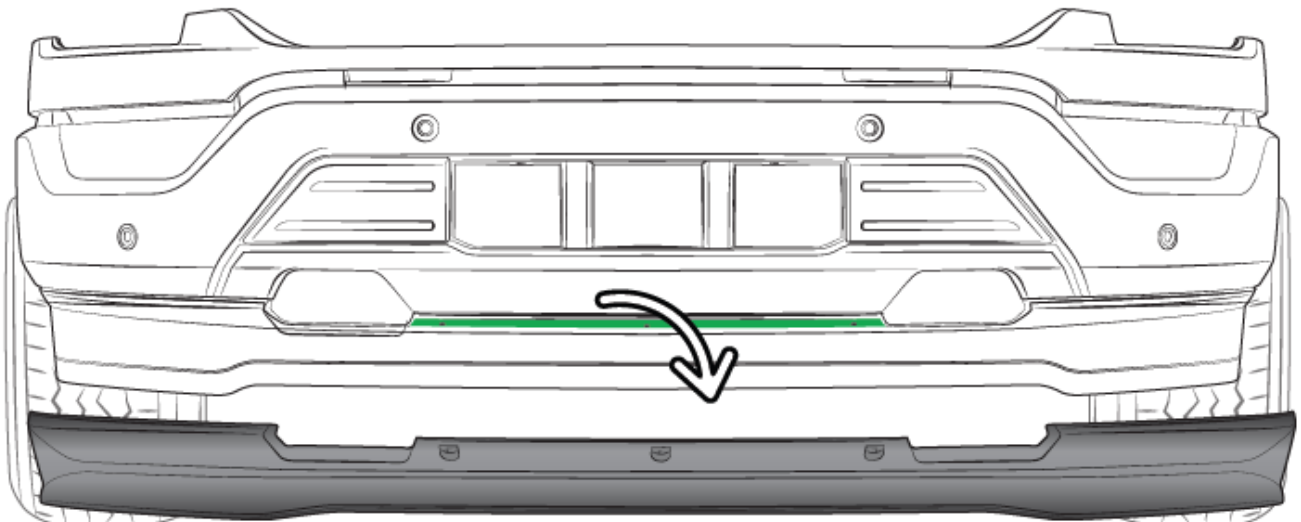

Ford Factory Shop Manual purchase options www.motorcraftservice.com



FORD **PERFORMANCE**

M-F150-FPS7 (Classic)
F-150 (4X4 Regular Cab & 4X2 Regular Cab)
FP700S Package

NO PART OF THIS DOCUMENT MAY BE REPRODUCED WITHOUT PRIOR AGREEMENT AND WRITTEN PERMISSION OF FORD PERFORMANCE PARTS © Ford Motor Company 2020

5 DRILL / BARRENE / PERCEZ



DRILL ON THE MARKS CAREFULLY.

DRILLING IS ONLY THROUGH THE PLASTIC PART.
DO NOT DRILL THROUGH THE SHEETMETAL.

AFTER DRILLING, REMOVE THE MASKING TAPE.

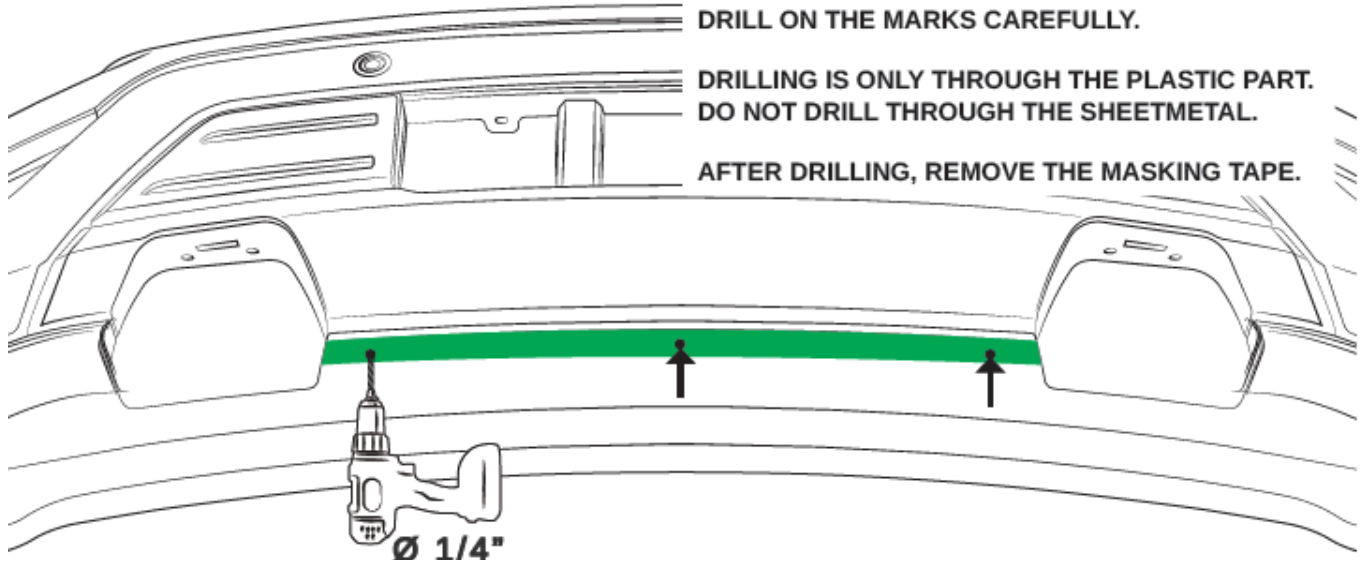

6 CLEAN / LIMPIE / NETTOYEZ



CLEAN THE INSTALLATION ZONE AGGRESSIVELY WITH ISOPROPYL ALCOHOL (91%) AND PAPER TOWELS. DRY THOROUGHLY!

CLEAN ALL AREAS WHERE THE DOUBLE SIDED TAPE AND THE POLYURETHANE ADHESIVE WILL MAKE CONTACT. ALL INSTALLATION AREAS MUST BE COMPLETELY FREE OF ANY DETERGENT, WAX OR DETAILING RESIDUE FOR PROPER ADHESION.

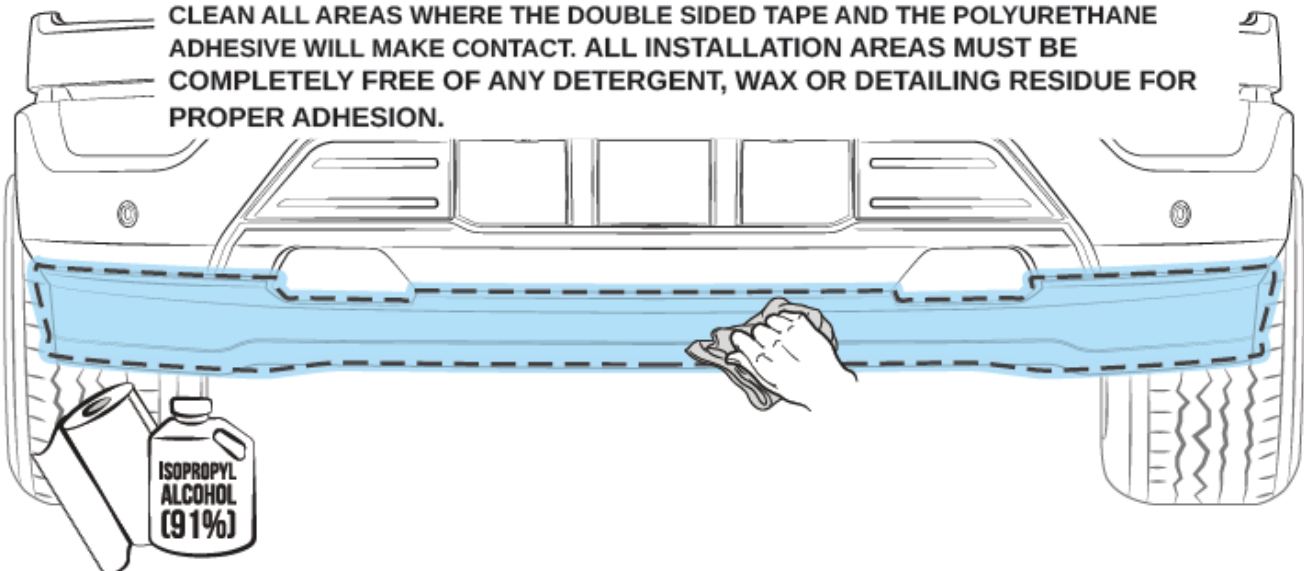

Ford Factory Shop Manual purchase options www.motorcraftservice.com



FORD PERFORMANCE

M-F150-FPS7 (Classic)
F-150 (4X4 Regular Cab & 4X2 Regular Cab)
FP700S Package

NO PART OF THIS DOCUMENT MAY BE REPRODUCED WITHOUT PRIOR AGREEMENT AND WRITTEN PERMISSION OF FORD PERFORMANCE PARTS © Ford Motor Company 2020

7 ADHESION PROMOTER



BEFORE APPLYING ADHESION PROMOTER MAKE SURE WARM SURFACE WITH HEAT GUN IF SURFACE TEMPERATURE IS TOO COLD. TAPE AND VEHICLE SURFACES SHOULD BE THE SAME TEMPERATURE AND MUST BE AT LEAST 60°F (16°C) DURING INSTALLATION! APPLY ADHESION PROMOTER.

APPLY ON ALL AREAS WHERE THE DOUBLE SIDED TAPE WILL MAKE CONTACT.

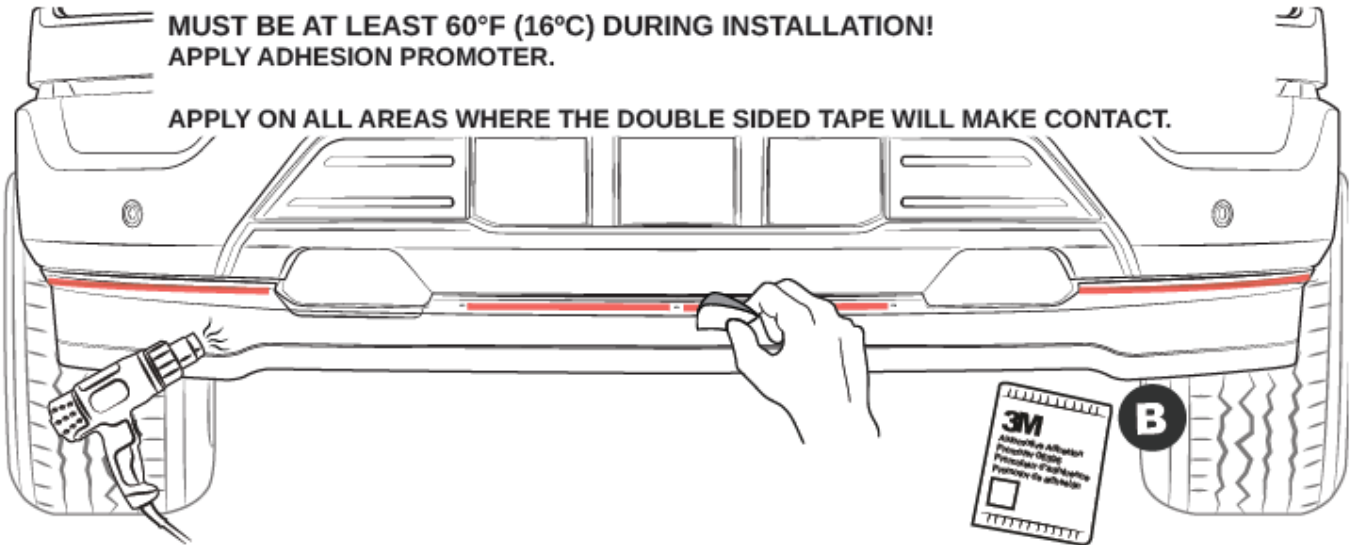

8 CLEAN ADHESIVE CHANNEL

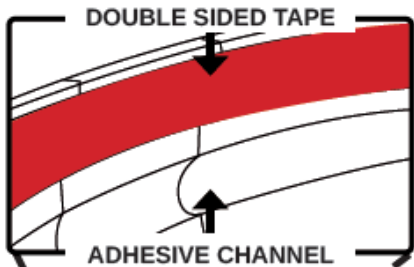

CLEAN THOROUGHLY TO ENSURE PROPER ADHESION.

CLEAN WITH ISOPROPYL ALCOHOL (91%) AND PAPER TOWELS.

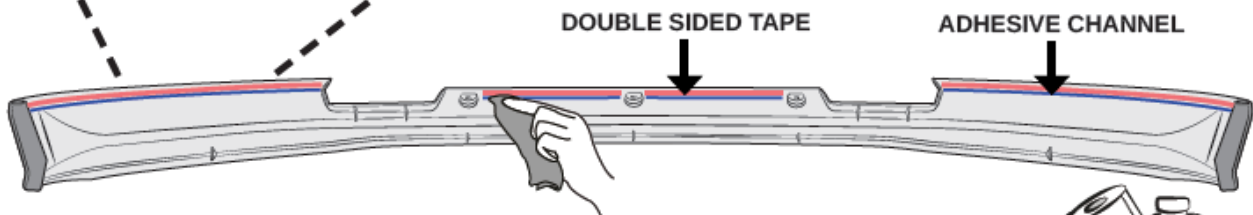

Inner view
Vista interior
Vue de l'intérieur



Ford Factory Shop Manual purchase options www.motorcraftservice.com



FORD PERFORMANCE

M-F150-FPS7 (Classic)
F-150 (4X4 Regular Cab & 4X2 Regular Cab)
FP700S Package

NO PART OF THIS DOCUMENT MAY BE REPRODUCED WITHOUT PRIOR AGREEMENT AND WRITTEN PERMISSION OF FORD PERFORMANCE PARTS © Ford Motor Company 2020

9 APPLY POLYURETHANE TO ADHESIVE CHANNEL

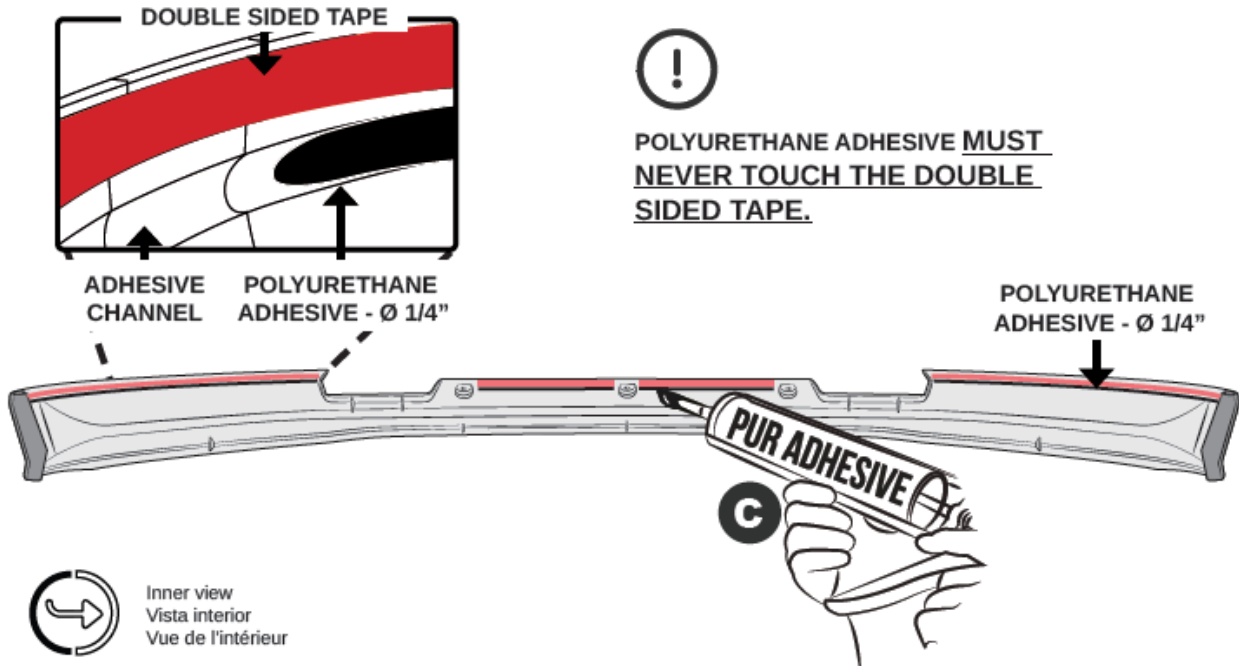

10 PEEL THE LINER / DESPEGUE LINER / DÉCOLLEZ LA DOUBLURE

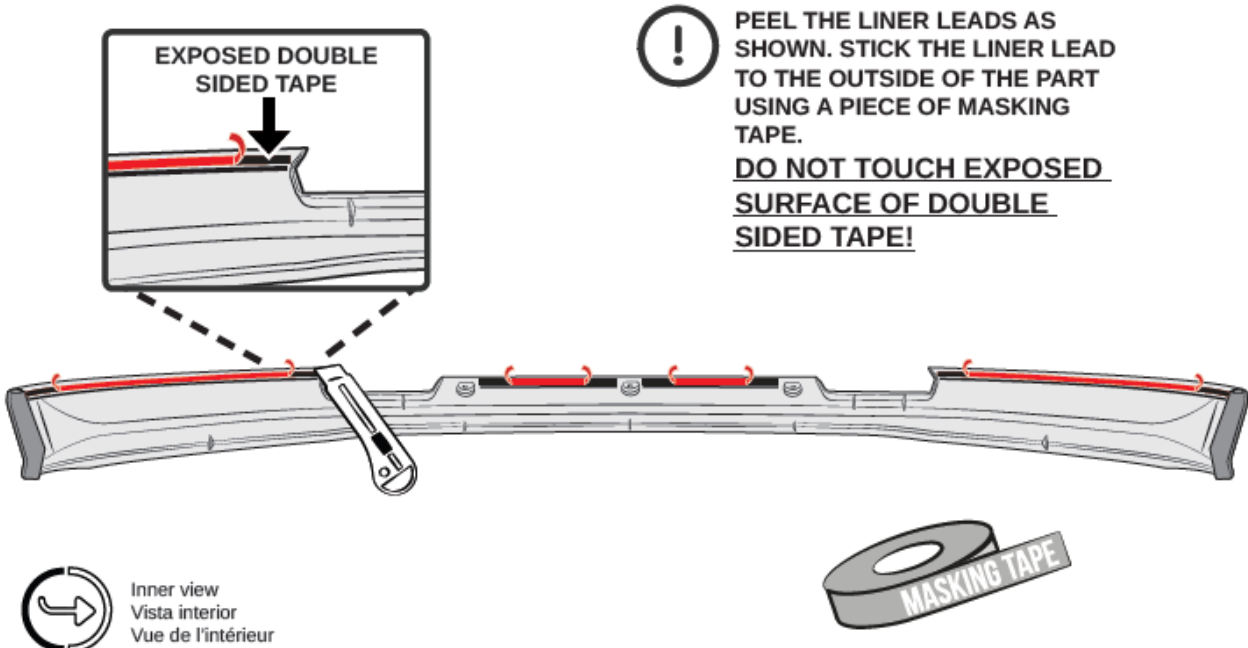

Ford Factory Shop Manual purchase options www.motorcraftservice.com



FORD **PERFORMANCE**

M-F150-FPS7 (Classic)
F-150 (4X4 Regular Cab & 4X2 Regular Cab)
FP700S Package

NO PART OF THIS DOCUMENT MAY BE REPRODUCED WITHOUT PRIOR AGREEMENT AND WRITTEN PERMISSION OF FORD PERFORMANCE PARTS © Ford Motor Company 2020

11 PLACE THE PART / COLOQUE LA PIEZA / PLACEZ LA PIÈCE

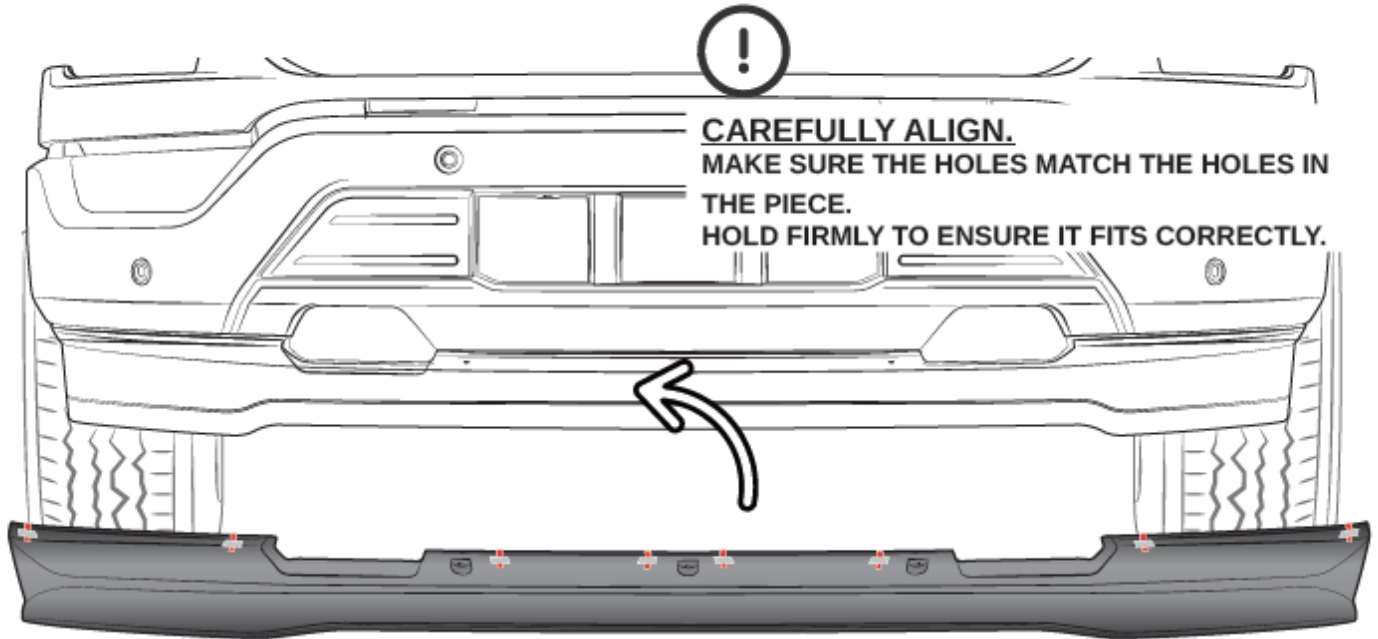

12 REMOVE THE LINER / RETIRE EL LINER / TIREZ LA DOUBLURE

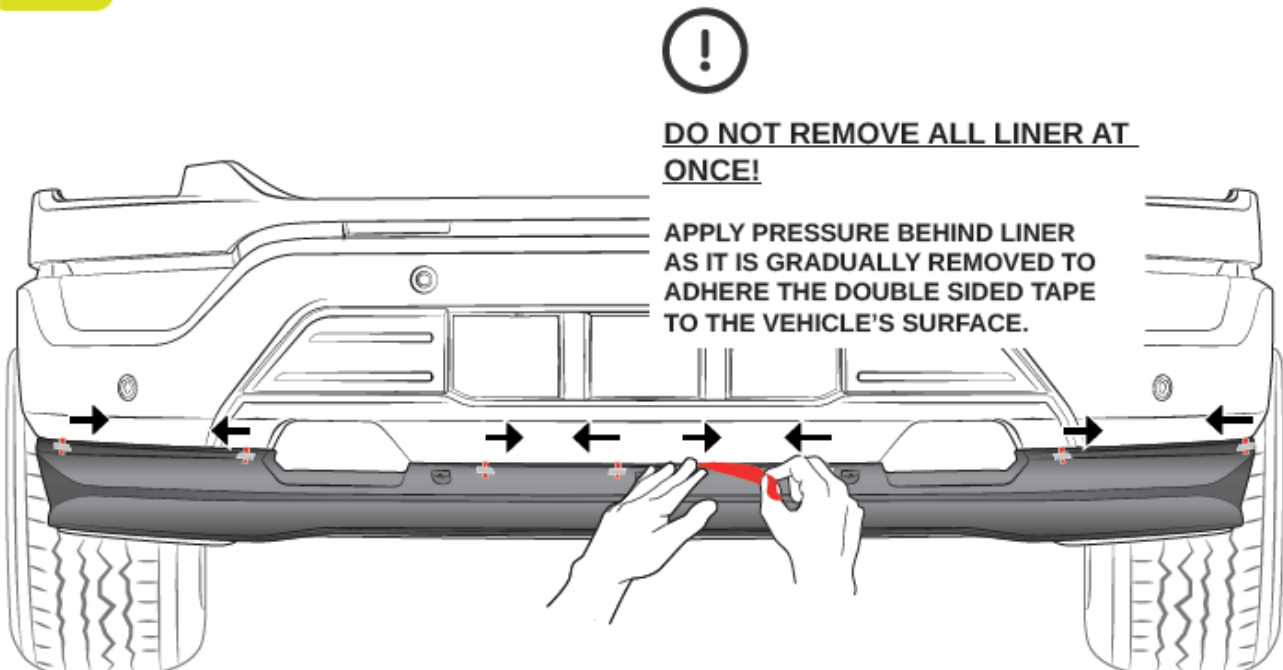

Ford Factory Shop Manual purchase options www.motorcraftservice.com



FORD **PERFORMANCE**

M-F150-FPS7 (Classic)
F-150 (4X4 Regular Cab & 4X2 Regular Cab)
FP700S Package

NO PART OF THIS DOCUMENT MAY BE REPRODUCED WITHOUT PRIOR AGREEMENT AND WRITTEN PERMISSION OF FORD PERFORMANCE PARTS © Ford Motor Company 2020

13 PRESS / PRESIONE / APPUYEZ



APPLY AS MUCH PRESSURE AS POSSIBLE TO THE ENTIRE CONTACT AREA WITH A MICROFIBER CLOTH.

FULL AND COMPLETE CONTACT BETWEEN TAPE AND VEHICLE SURFACE IS CRUCIAL FOR GOOD ADHESION PERFORMANCE. TAPE IS PRESSURE AND TEMPERATURE SENSITIVE.

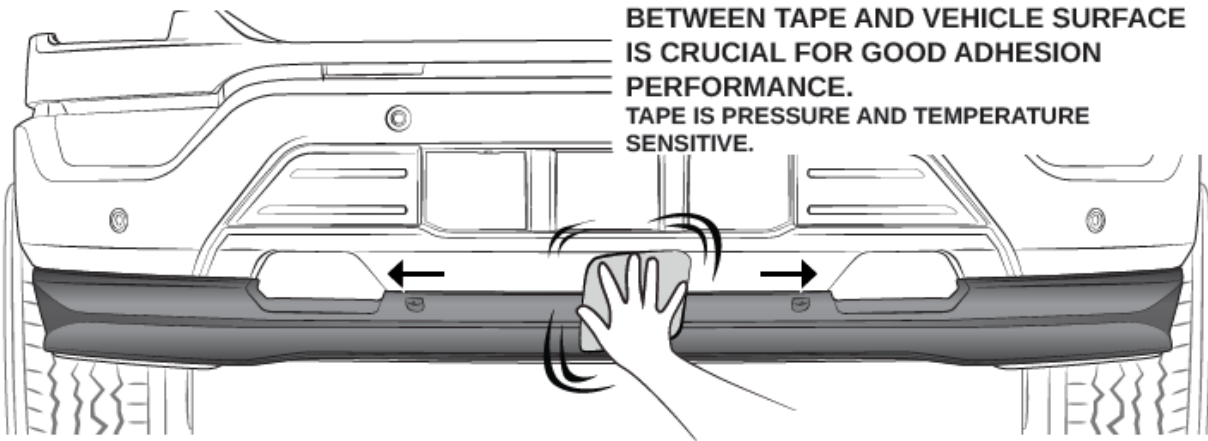

14 SECURE / ASEGURE / FIXEZ



CAREFULLY SECURE WITH INCLUDED PUSH PINS.

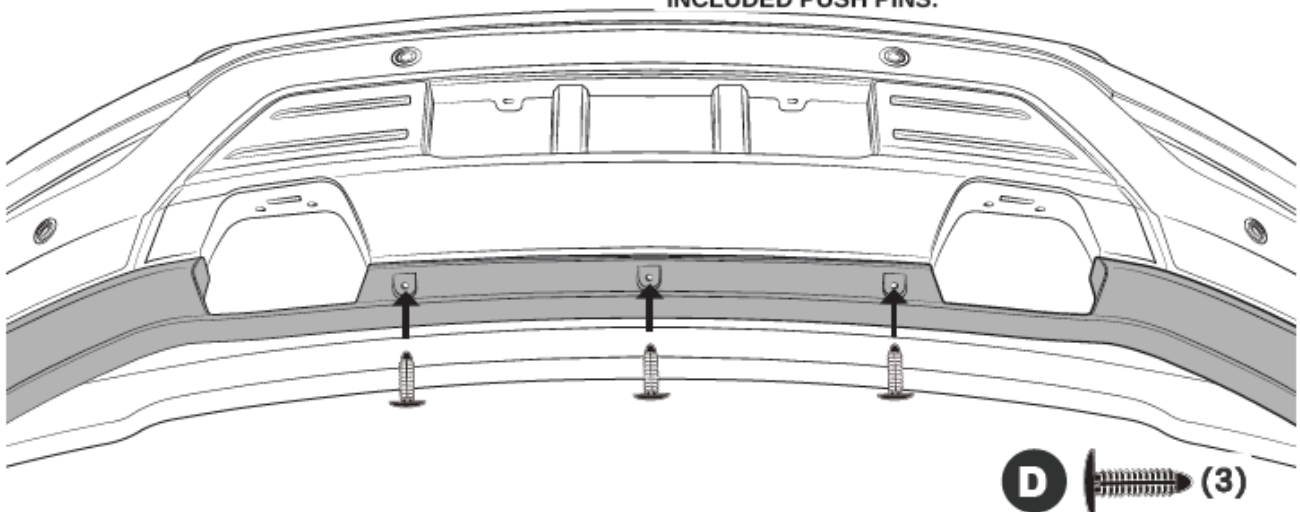

Ford Factory Shop Manual purchase options www.motorcraftservice.com



FORD **PERFORMANCE**

M-F150-FPS7 (Classic)
F-150 (4X4 Regular Cab & 4X2 Regular Cab)
FP700S Package

NO PART OF THIS DOCUMENT MAY BE REPRODUCED WITHOUT PRIOR AGREEMENT AND WRITTEN PERMISSION OF FORD PERFORMANCE PARTS © Ford Motor Company 2020

12 CLEAN / LIMPIE / NETTOYEZ



REMOVE MARKINGS AND CLEAN CAREFULLY.

CLEAN WITH ISOPROPYL ALCOHOL (91%) AND PAPER TOWELS.

AFTER THE INSTALLATION DO NOT WASH OR PRESSURE WASH.

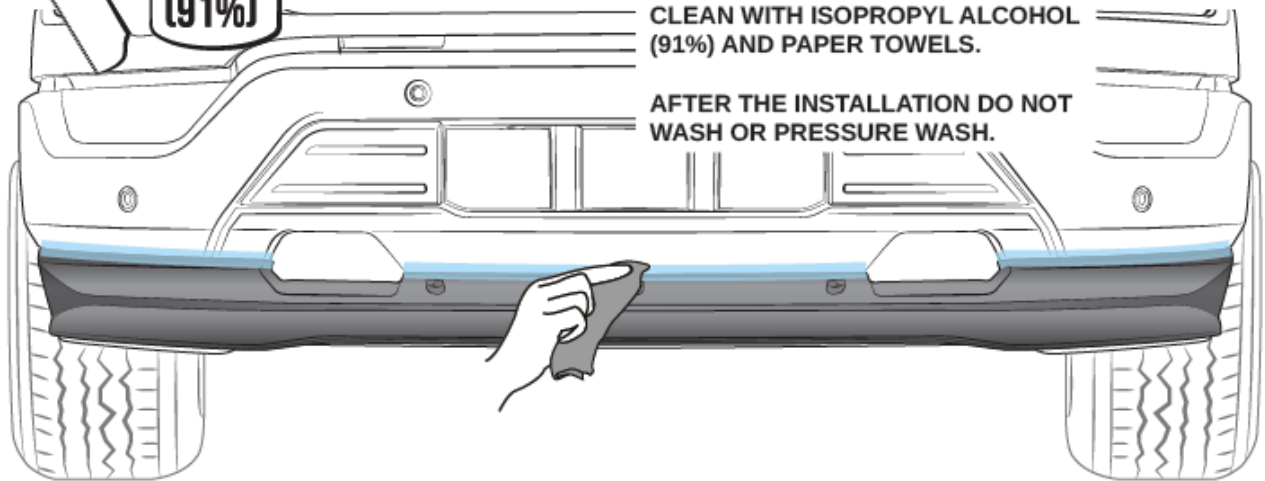

INSTALLED PART
PIEZA INSTALADA
PIÈCE INSTALLÉE

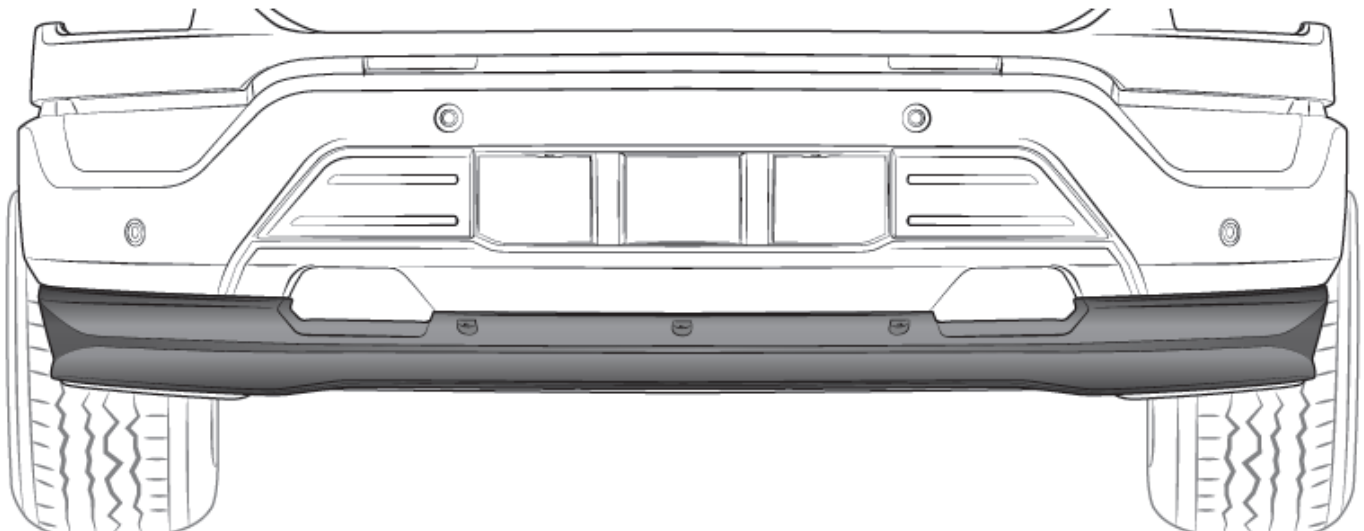

Ford Factory Shop Manual purchase options www.motorcraftservice.com



FORD **PERFORMANCE**

M-F150-FPS7 (Classic)
F-150 (4X4 Regular Cab & 4X2 Regular Cab)
FP700S Package

NO PART OF THIS DOCUMENT MAY BE REPRODUCED WITHOUT PRIOR AGREEMENT AND WRITTEN PERMISSION OF
FORD PERFORMANCE PARTS © Ford Motor Company 2020

9. 5.0L Supercharger

Follow the instruction sheet for kit **M-6066-F150SCA**.

https://performanceparts.ford.com/download/instructionsheets/IS_M-6066-F150SCA_100724.PDF

Ford Factory Shop Manual purchase options www.motorcraftservice.com



FORD PERFORMANCE

M-F150-FPS7 (Classic)
F-150 (4X4 Regular Cab & 4X2 Regular Cab)
FP700S Package

NO PART OF THIS DOCUMENT MAY BE REPRODUCED WITHOUT PRIOR AGREEMENT AND WRITTEN PERMISSION OF
FORD PERFORMANCE PARTS © Ford Motor Company 2020

10. FP700S Regular Cab Suspension Kit

WARNING

MODIFYING AN ORIGINAL EQUIPPED VEHICLE WILL RESULT IN A VEHICLE HANDLING DIFFERENTLY. ALL TYPES OF SUSPENSION MODIFICATIONS WILL AFFECT REACTION, RIDE, HANDLING AND WEAR AND TEAR RATE OF A VEHICLE AND ITS COMPONENTS. ABRUPT MANEUVERS, SHARP AND SUDDEN TURNS AND WEATHER CONDITIONS WILL INCREASE THE VEHICLE'S SUSCEPTIBILITY FOR LOSS OF CONTROL. DEATH AND SERIOUS INJURY COULD BE THE RESULT IF YOU FAIL TO OPERATE A MODIFIED VEHICLE SAFELY. KNOW AND FOLLOW THE LAWS OF THE STATES.

READ INSTRUCTIONS COMPLETELY THROUGH BEFORE STARTING.

FAILURE TO ADHERE TO THE INSTRUCTIONS WILL VOID ANY GROUND FORCE WARRANTY
IT IS RECOMMENDED THAT INSTALLATION BE DONE BY A QUALIFIED MECHANIC.

REPLACE ALL STOCK PARTS THAT ARE DAMAGED OR WORN.

INTERMIXING OF PARTS IS NOT RECOMMENDED AND WILL VOID THE WARRANTY.

ALWAYS WEAR EYE PROTECTION.

ALWAYS USE PROPERLY RATED SAFETY STANDS WHENEVER A PROCEDURE REQUIRES
YOU TO BE UNDER A VEHICLE. KNOW AND FOLLOW ALL SAFE WORK PRACTICES TO AVOID
SERIOUS INJURY OR DEATH.

Ford Factory Shop Manual purchase options www.motorcraftservice.com



FORD PERFORMANCE

M-F150-FPS7 (Classic)
F-150 (4X4 Regular Cab & 4X2 Regular Cab)
FP700S Package

NO PART OF THIS DOCUMENT MAY BE REPRODUCED WITHOUT PRIOR AGREEMENT AND WRITTEN PERMISSION OF
FORD PERFORMANCE PARTS © Ford Motor Company 2020

CHECK TO SEE THAT ALL PARTS LISTED ARE INCLUDED.

1-INSTRUCTION SHEET
1-GROUND FORCE WARNING DECAL
2-SHACKLES
2-FRONT SHOCKS
2-BLUE PAINTED FRONT LOWERING SPRINGS
2-REAR AXLE SHIMS
4 W520214-S440 NUTS
2 W520215-S441 SWAY BAR ENDLINK NUTS
2 W712134-S440 SHOCK ROD NUTS
2 W717969-S440 UPPER CONTROL ARM NUTS
4-UBOLTS
8-WASHERS
8-UBOLT NUTS
4-URETHANE SHACKLE BUSHINGS
2-SHACKLE SLEEVES
2-GREASE FITTINGS

Ford Factory Shop Manual purchase options www.motorcraftservice.com

NO PART OF THIS DOCUMENT MAY BE REPRODUCED WITHOUT PRIOR AGREEMENT AND WRITTEN PERMISSION OF FORD PERFORMANCE PARTS © Ford Motor Company 2020

NOTE: AMOUNT OF DROP APPROXIMATE DUE TO FACTORY OPTIONS.

MEASURE AND DOCUMENT THE VEHICLE HEIGHT FROM FLOOR TO FENDER LIP.

LF _____ RF _____ LR _____ RR _____

1. BEFORE GETTING UNDER VEHICLE, REMOVE THE KEYS FROM THE IGNITION. DISCONNECT THE NEGATIVE BATTERY TERMINAL FROM THE BATTERY. DO NOT MOVE THE STEERING OR TIE RODS LEFT OR RIGHT WHILE DOING THIS INSTALLATION AS **MISALIGNMENT OF THE ELECTRONIC STEERING SYSTEM** MAY RESULT. JACK THE FRONT OF VEHICLE UP AND PLACE STANDS UNDER THE FRAME RAILS. LOWER THE VEHICLE ONTO JACK STANDS AND MAKE SURE STANDS ARE SECURELY HOLDING THE VEHICLE.
2. REMOVE TIRE AND WHEEL ASSEMBLY.
3. REMOVE THE UPPER CONNECTING LINK HARDWARE FROM THE SWAY BAR ON BOTH SIDES OF VEHICLE,



UPPER SWAY
BAR LINK
HARDWARE

SPLASH
SHIELD



4. LOCATE THE SPLASH SHIELD BEHIND THE LOWER CONTROL ARM REAR BOLTS AND REMOVE THE FOUR BOLTS HOLDING THE SPLASH SHIELD TO THE FRAME BRACKETS (THIS WILL ALLOW YOU TO LOOSEN AND REMOVE THE REAR SET OF LOWER CONTROL ARM BOLTS).
5. LOOSEN THE OUTER TIE ROD NUT, TAP ON THE SPINDLE WITH A MALLET TO POP THE TIE ROD JOINT LOOSE FROM THE SPINDLE. REMOVE THE OUTER TIE ROD FROM THE SPINDLE, SAVE NUT, REPEAT TO THE OTHER SIDE OF VEHICLE.

NO PART OF THIS DOCUMENT MAY BE REPRODUCED WITHOUT PRIOR AGREEMENT AND WRITTEN PERMISSION OF FORD PERFORMANCE PARTS © Ford Motor Company 2020

6. THE LOWER CONTROL ARM FRAME MOUNTS HAVE FACTORY ALIGNMENT SLOTS AND MUST BE MARKED BEFORE LOOSING. THIS PROCEDURE WILL AID IN ADJUSTING THESE BOLTS BACK TO THE CORRECT LOCATION DURING FINAL ASSEMBLY. **REFER TO THE PHOTO BELOW**

A. USING A PAINT STICK MARK ALL FOUR LOWER CONTROL ARM MOUNTING BOLT LOCATIONS.

B. LOOSEN BUT DO NOT REMOVE THE FOUR LOWER CONTROL ARM TO FRAME MOUNT BOLTS. THIS NEEDS TO BE DONE SO THAT THE LOWER CONTROL ARM WILL SWING DOWN FAR ENOUGH TO BE ABLE TO REMOVE THE STRUT ASSEMBLY FROM THE VEHICLE. SUPPORT THE LOWER CONTROL ARM.



LOWER CONTROL ARM TO FRAME MOUNTING HARDWARE.

PAINT STICK MARK SHOWING FACTORY HARDWARE LOCATION.

7. MARK THE UPPER AND LOWER STRUT MOUNTS SO THAT WHEN YOU INSTALL THE NEW SHOCK ABSORBER YOU WILL BE ABLE TO ALIGN THE UPPER AND LOWER STRUT MOUNTS IN THEIR CORRECT LOCATION. MARK THE STRUT ASSEMBLY LEFT AND RIGHT.



UPPER AND LOWER STRUT INDEX MARKS



8. LOOSEN AND REMOVE THE TWO LOWER STRUT MOUNTING NUTS LOCATED UNDER THE LOWER CONTROL ARM, SAVE HARDWARE.



LOWER STRUT MOUNTING HARDWARE LOCATION.

WARNING: THE COIL SPRING ASSEMBLY IS UNDER PRESSURE, DO NOT REMOVE THE CENTER UPPER STRUT ROD NUT.

NO PART OF THIS DOCUMENT MAY BE REPRODUCED WITHOUT PRIOR AGREEMENT AND WRITTEN PERMISSION OF FORD PERFORMANCE PARTS © Ford Motor Company 2020

9. LOOSEN THE UPPER THREE **OUTER** NUTS ATTACHING THE STRUT ASSEMBLY TO THE VEHICLE FRAME.
10. SUPPORT THE LOWER CONTROL ARM NOTE THE DIRECTION OF THE MOUNTING HARDWARE THAT ATTACHES THE LOWER CONTROL ARM A TO FRAME MOUNTS. REMOVE THE LOWER CONTROL ARM TO FRAME HARDWARE (**REFER TO PHOTOS BELOW**).
11. LOWER THE JACK SLIGHTLY UNDER THE LOWER CONTROL ARM, REMOVE THE UPPER OUTER THREE STRUT TO FRAME NUTS AND REMOVE THE STRUT ASSEMBLY FROM THE VEHICLE. SAVE HARDWARE.

DRIVERS SIDE FRONT SHOWN WITH STRUT REMOVED

LOWER CONTROL ARM BEING LOWERED AWAY FROM LOWER STRUT MOUNTING STUDS



12. REPEAT STRUT REMOVAL PROCEDURE TO OTHER SIDE OF VEHICLE.
13. **NEW SHOCK AND SPRING INSTALLATION PROCEDURE.**

Ford Factory Shop Manual purchase options www.motorcraftservice.com

NO PART OF THIS DOCUMENT MAY BE REPRODUCED WITHOUT PRIOR AGREEMENT AND WRITTEN PERMISSION OF FORD PERFORMANCE PARTS © Ford Motor Company 2020

14. COIL SPRING INDEXING - MARK THE UPPER SPRING SEAT AND THE LOWER SPRING SEAT WITH INDEX MARKS TO THE TOP HAT FOR THE NEXT COUPLE OF STEPS. THE UPPER SPRING SEAT / TOP HAT AND THE LOWER SPRING SEAT WILL BE REUSED ON THE NEW SHOCK AND SPRING. THE ORIGINAL SHOCK AND SPRING WILL NOT BE RE-USED IN THIS KIT.
15. COMPRESS THE STRUT ASSEMBLY STOCK COIL SPRING USING A STRUT/COILOVER COMPRESSOR. FOLLOW THE STRUT/COILOVER COMPRESSOR INSTRUCTIONS.

WARNING: THE COIL IS UNDER PRESSURE. EXTREME CARE MUST BE TAKEN WHEN REMOVING AND INSTALLING THE COILS TO AVOID INJURY.

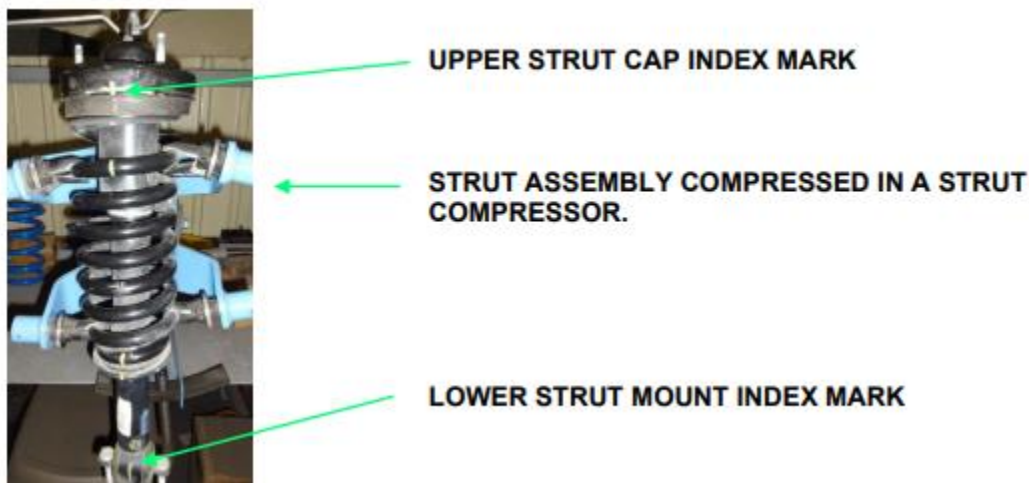

16. ONCE THE SPRING IS COMPRESSED REMOVE THE CENTER UPPER STRUT ROD NUT WHILE HOLDING THE STRUT SHAFT FROM SPINNING INSIDE OF THE STRUT. SAVE HARDWARE
- A. REMOVE THE UPPER STRUT MOUNT FROM THE STRUT.
 - B. REMOVE THE UPPER RUBBER SPRING SEAT FROM THE STRUT.
 - C. REMOVE THE STRUT FROM THE COIL SPRING.
 - D. REMOVE THE STOCK COIL IN THE STRUT/COILOVER COMPRESSOR.
 - E. COMPRESS THE NEW FORD PERFORMANCE LOWERING SPRING.
 - F. SEE NEXT DIAGRAM FOR ASSEMBLY OVERVIEW OF THE SHOCK MODULE



FORD PERFORMANCE

M-F150-FPS7 (Classic)
F-150 (4X4 Regular Cab & 4X2 Regular Cab)
FP700S Package

NO PART OF THIS DOCUMENT MAY BE REPRODUCED WITHOUT PRIOR AGREEMENT AND WRITTEN PERMISSION OF FORD PERFORMANCE PARTS © Ford Motor Company 2020

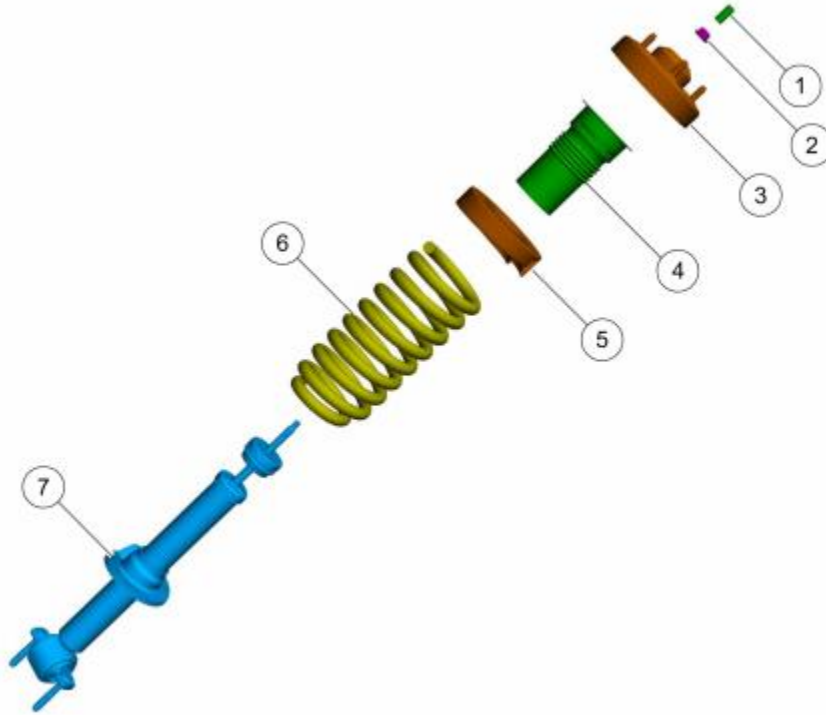

E338076

Ford Factory Shop Manual purchase options www.motorcraftservice.com



FORD PERFORMANCE

M-F150-FPS7 (Classic)
F-150 (4X4 Regular Cab & 4X2 Regular Cab)
FP700S Package

NO PART OF THIS DOCUMENT MAY BE REPRODUCED WITHOUT PRIOR AGREEMENT AND WRITTEN PERMISSION OF
FORD PERFORMANCE PARTS © Ford Motor Company 2020

17. COIL TO STRUT SHOCK INSTALLATION PROCEDURE. FOLLOW THE STRUT/COILOVER COMPRESSOR INSTRUCTIONS.

WARNING: THE COIL IS UNDER PRESSURE. EXTREME CARE MUST BE TAKEN WHEN AND INSTALLING THE COILS TO AVOID INJURY.

B. INSTALL THE NEW STRUT UP THROUGH THE NOW COMPRESSED FORD PERFORMANCE LOWERING SPRING COIL.

A. INSTALL THE STOCK UPPER RUBBER ISOLATOR AND TOP HAT ONTO THE TOP OF THE COIL. MAKE SURE THAT THE UPPER COIL IS LOCATED AGAINST THE UPPER COIL STOP AND THAT THE RUBBER ISOLATOR IS LOCATED CORRECTLY IN THE SPRING SEAT. **SEE THE PHOTO BELOW (on next page)**

E. INSTALL THE UPPER STRUT CENTER RETAINING NUT TO THE STRUT SHAFT AND TORQUE THE STRUT SHAFT RETAINING NUT TO SPEC OF 41 Ft/lbs (55Nm)

F. ONCE THAT YOU ARE SURE THE COIL IS LOCATED CORRECTLY ON THE STRUT REMOVE THE STRUT/COIL ASSEMBLY FROM THE COMPRESSOR. FOLLOW THE STRUT COMPRESSOR INSTRUCTIONS.

G. REPEAT COIL INSTALLATION TO THE OTHER STRUT.

NOTE: Make sure the "ID Label" and paint dot is located at lower end of the installed coil spring.

Make sure that the lower spring seat is properly installed.
Use the General Equipment: Spring Compressor

Ford Factory Shop Manual purchase options www.motorcraftservice.com



FORD PERFORMANCE

M-F150-FPS7 (Classic)
F-150 (4X4 Regular Cab & 4X2 Regular Cab)
FP700S Package

NO PART OF THIS DOCUMENT MAY BE REPRODUCED WITHOUT PRIOR AGREEMENT AND WRITTEN PERMISSION OF FORD PERFORMANCE PARTS © Ford Motor Company 2020

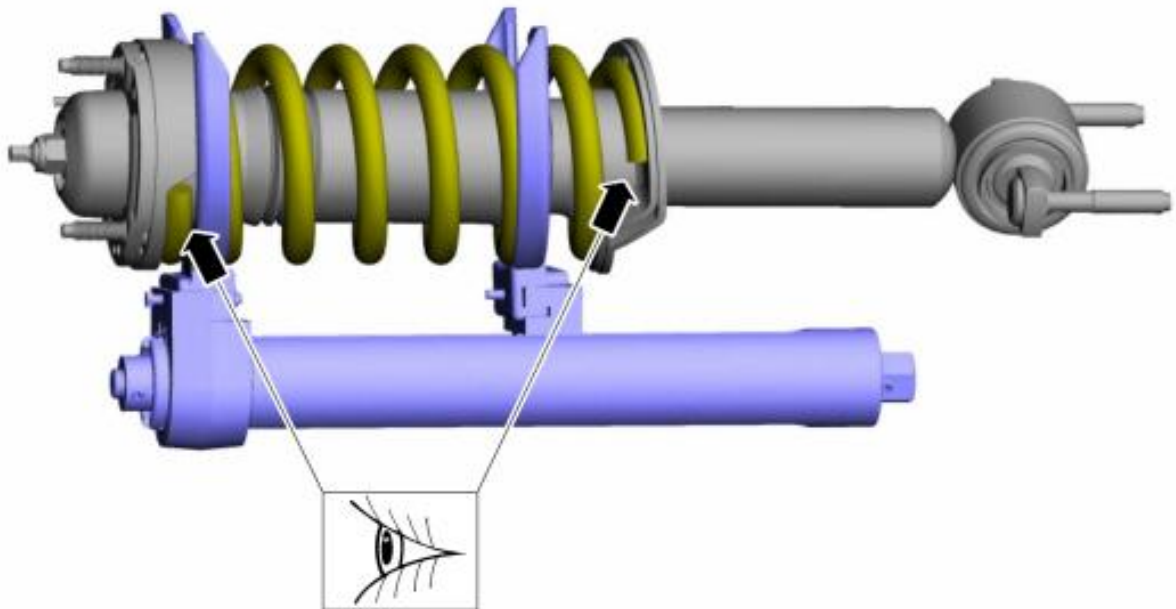

E293485

Ford Factory Shop Manual purchase options www.motorcraftservice.com



M-F150-FPS7 (Classic)
F-150 (4X4 Regular Cab & 4X2 Regular Cab)
FP700S Package

NO PART OF THIS DOCUMENT MAY BE REPRODUCED WITHOUT PRIOR AGREEMENT AND WRITTEN PERMISSION OF
FORD PERFORMANCE PARTS © Ford Motor Company 2020

18. STRUT TO VEHICLE INSTALLATION.
 - A. INSTALL THE STRUT ASSEMBLY UP INTO THE STOCK LOCATION.
 - B. ALIGN AND INSTALL THE THREE STUDS UP INTO THE THREE HOLES IN THE FRAME UPPER MOUNT.
 - C. INSTALL THE FACTORY THREE UPPER STRUT LOCKNUTS (JUST **START** THE NUTS AS THE UPPER STRUT MOUNT WILL NEED TO MOVE SOME WHEN THE LOWER STRUT STUDS ARE BEING LINED UP WITH THE LOWER CONTROL ARM).
 - D. JACK UP THE LOWER CONTROL ARM AND LINE UP THE LOWER STRUT MOUNTING STUDS INTO THE LOWER CONTROL ARM AND JUST START THE FACTORY LOWER STRUT RETAINING NUTS.
 - E. CONTINUE TO JACK UP THE LOWER CONTROL ARM LINING UP THE CONTROL ARM INTO THE FRAME MOUNTING POCKETS, REINSTALL THE FACTORY LOWER CONTROL ARM TO FRAME MOUNTING HARDWARE IN THE SAME DIRECTION AS REMOVED **JUST START** THE NUTS.
 - F. INSTALL THE CONNECTING LINK UP INTO THE SWAY BAR AND **JUST START** THE FACTORY RETAINING NUT.
 - G. REPEAT STRUT INSTALLATION PROCEDURE TO THE OTHER SIDE OF VEHICLE.
 - I. TORQUE THE LOWER STRUT MOUNTING HARDWARE TO THE TORQUE SPEC OF 66FT/LBs.
19. REPOSITION THE JACK OUT TOWARD THE SPINDLE SIDE OF THE LOWER CONTROL ARM AND JACK THE SUSPENSION UP TO RIDE HEIGHT (MAKE SURE YOUR SAFETY STANDS ARE SECURE UNDER THE VEHICLE). WITH THE HELP OF AN ASSISTANT LINE UP THE LOWER CONTROL ARM MOUNTING HARDWARE TO THE MARKS MADE IN STEP NO 6 AND TORQUE THE LOWER CONTROL ARM TO FRAME MOUNTING BOLTS TO THE TORQUE SPEC OF 258ft/lbs (350Nm). REPEAT TO THE OTHER SIDE OF VEHICLE.
20. TORQUE THE UPPER THREE STRUT NUTS TO THE TORQUE SPEC OF 52FT/lbs (70Nm)
21. WITH THE STRUT AND LOWER CONTROL ARM NOW TIGHTENED TO SPEC LOWER THE JACK UNDER THE LOWER CONTROL ARM UNTIL THE SUSPENSION IS FREE HANGING (4X4 MODELS).R
 - A. WITH THE STEERING TIE RODS **STILL DISCONNECTED** TURN THE STEERING KNUCKLES FROM COMPLETE LEFT LOCK TO COMPLETE RIGHT LOCK BY HAND AND VERIFY THAT YOU HAVE **CLEARANCE** BETWEEN THE LOWER STRUT MOUNT AND THE OUTER CV BOOT AS SHOWN BELOW. THIS SYSTEM WAS DESIGNED TO HAVE CLEARANCE WITH FACTORY CV BOOTS.

Ford Factory Shop Manual purchase options www.motorcraftservice.com



FORD PERFORMANCE

M-F150-FPS7 (Classic)
F-150 (4X4 Regular Cab & 4X2 Regular Cab)
FP700S Package

NO PART OF THIS DOCUMENT MAY BE REPRODUCED WITHOUT PRIOR AGREEMENT AND WRITTEN PERMISSION OF FORD PERFORMANCE PARTS © Ford Motor Company 2020



**4X4 MODELS
CLEARANCE BEING
CHECKED BETWEEN THE
OUTER CV BOOT AND
THE LOWER STRUT
MOUNT. MAINTAIN A
MINIMUM OF 1/8" AT THE
CLOSEST POINT WITH
THE SUSPENSION
HANGING IN THE FULL
DROOP POSITION.**

23. REINSTALL THE TIE RODS TO THE SPINDLES AND TORQUE TO THE SPEC OF 66Ft/lbs (90Nm)
24. TORQUE THE UPPER CONNECTING LINK NUTS TO SPEC OF 150Ft/lbs (150Nm) ON BOTH SIDES OF THE VEHICLE.
25. REINSTALL THE SPLASH SHIELD INTO THE FACTORY POSITION AND INSTALL THE FACTORY HARDWARE AND TORQUE TO SPEC.
26. MAKE SURE ALL FASTENERS AFFECTED BY THIS PROCEDURE ARE TORQUED TO SPEC.
27. REINSTALL TIRE AND WHEEL ASSEMBLY AND TORQUE TO SPEC OF 150Ft/lbs
28. CHECK AND MAKE SURE THAT ALL INSTALLATION STEPS HAVE BEEN COMPLETED. CHECK ALL NUTS AND BOLTS FOR TORQUE AFTER THE FIRST 300 MILES.
29. JACK THE VEHICLE UP AND REMOVE STANDS, THEN LET THE VEHICLE DOWN AND RECONNECT THE NEGATIVE BATTERY TERMINAL ON THE BATTERY.
30. MAKE SURE THERE ARE NO CLEARANCE PROBLEMS. ROTATE THE STEERING LOCK TO LOCK UNDER FULL WEIGHT OF THE VEHICLE AND FULL SUSPENSION TRAVEL.

Ford Factory Shop Manual purchase options www.motorcraftservice.com

NO PART OF THIS DOCUMENT MAY BE REPRODUCED WITHOUT PRIOR AGREEMENT AND WRITTEN PERMISSION OF FORD PERFORMANCE PARTS © Ford Motor Company 2020

REAR INSTALL

NOTE: AMOUNT OF DROP APPROXIMATE DUE TO FACTORY OPTIONS AND OR AFTERMARKET OPTIONS.

31. JACK UP THE REAR OF THE VEHICLE AND PLACE JACK STANDS UNDER THE FRAME RAILS. LOWER THE VEHICLE ONTO THE JACK STANDS AND MAKE SURE THE STANDS ARE SECURELY HOLDING THE VEHICLE. SUPPORT THE REAR AXLE WITH A FLOOR JACK AND SMALL JACK STANDS.
32. REMOVE THE REAR TIRE WHEEL ASSEMBLY.

WARNING: THE LEAF SPRINGS ARE UNDER PRESSURE. EXTREME CARE MUST BE TAKEN WHEN WORKING WITH THE SPRINGS TO AVOID INJURY.

33. SUPPORT THE REAR AXLE.
34. REMOVE THE STOCK REAR SHOCKS FROM THE LOWER MOUNTS, SAVE HARDWARE.
35. REMOVE THE U-BOLTS FROM ONE SIDE AND LET THE REAR AXLE DOWN UNTIL THE FACTORY BLOCK CAN BE REMOVED (IF EQUIPPED, BLOCK NOT PRESENT ON SOME 4X2 MODELS)
 - A. REMOVE THE FACTORY BLOCK AND DISCARD.
36. INSTALL THE WEDGE ON TOP OF THE AXLE WITH THE **THICKER END OF THE WEDGE TOWARD THE REAR OF THE VEHICLE.**

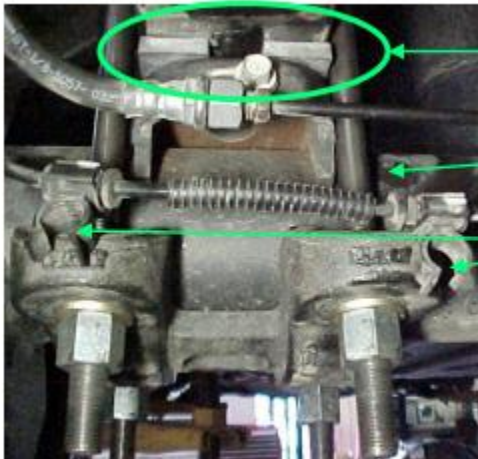

WEDGE INSTALLED WITH THE **THICK** END TOWARD THE **REAR** OF THE VEHICLE.

NEW U-BOLTS

PLASTIC RETAINING CLIPS



FORD PERFORMANCE

M-F150-FPS7 (Classic)
F-150 (4X4 Regular Cab & 4X2 Regular Cab)
FP700S Package

NO PART OF THIS DOCUMENT MAY BE REPRODUCED WITHOUT PRIOR AGREEMENT AND WRITTEN PERMISSION OF
FORD PERFORMANCE PARTS © Ford Motor Company 2020

37. JACK THE AXLE UP AND LINE UP THE CENTER PIN HEADS THROUGH THE WEDGES AND INTO THE AXLE PIN HOLES.
- A. INSTALL THE NEW U-BOLTS AND U-BOLT HARDWARE.
 - A. SNUG THE U-BOLT NUTS MAKING SURE THE CENTER PIN HEADS STAY IN THE AXLE CENTER PIN HOLES.
 - B. REPEAT THE BLOCK REMOVAL AND WEDGE INSTALLATION TO THE OTHER SIDE OF THE VEHICLE.
 - C. TORQUE THE REAR LEAF SPRING IN A CROSS PATTERN IN THE FOLLOWING 4 STAGES
 - Stage 1: 30 lb.ft (40 Nm)
 - Stage 2: 59 lb.ft (80 Nm)
 - Stage 3: 89 lb.ft (120 Nm)
 - Stage 4: 111 lb.ft (150 Nm)
 - D. IF EQUIPPED REATTACH THE PLASTIC RETAINING CLIPS OVER THE U-BOLTS.

WARNING: THE LEAF SPRING ARE UNDER PRESSURE. EXTREME CARE MUST BE TAKEN WHEN REMOVING AND INSTALLING THE SHACKLES TO AVOID INJURY.

Ford Factory Shop Manual purchase options www.motorcraftservice.com

NO PART OF THIS DOCUMENT MAY BE REPRODUCED WITHOUT PRIOR AGREEMENT AND WRITTEN PERMISSION OF FORD PERFORMANCE PARTS © Ford Motor Company 2020

38. REAR SHACKLE REMOVAL. MAKE SURE THE JACK STANDS ARE SECURE UNDER THE VEHICLE FRAME.

A. NOTE THE STOCK SHACKLE HARDWARE LOCATION AND DIRECTION OF THE BOLT HEADS.

B. LOOSEN THE LOWER SHACKLE TO FRAME BOLT.

C. LOOSEN THE UPPER SHACKLE TO SPRING EYE BOLT.

D. WITH THE REAR AXLE SUPPORTED REMOVE THE LOWER SHACKLE BOLTS, SAVE ALL HARDWARE AS IT WILL BE REUSED. PLACE SOME DUCT TAPE ON THE REAR OF THE CROSSMEMBER AS SHOWN BELOW. JACK THE AXLE UP UNTIL THE UPPER SHACKLE BOLTS CAN BE REMOVED OVER THE TOP OF THE FRAME RAIL. THE LEAF SPRING REAR EYE WILL SLIDE UP **BEHIND** THE REAR BED CROSS MEMBER AS SHOWN BELOW. MAKE SURE THE VEHICLE IS SECURE ON THE STANDS AS YOU WILL HAVE TO PUT SOME PRESSURE ON THE JACK TO GET THE SHACKLE HIGH ENOUGH TO GET THE BOLTS TO SLIDE OUT OVER THE FRAME RAILS REMOVE THE UPPER SHACKLE BOLT AND REMOVE THE SHACKLE FROM THE VEHICLE.



UPPER SHACKLE
BOLT BEING
REMOVED OVER THE
TOP OF THE FRAME

Ford Factory Shop Manual purchase options www.motorcraftservice.com

NO PART OF THIS DOCUMENT MAY BE REPRODUCED WITHOUT PRIOR AGREEMENT AND WRITTEN PERMISSION OF FORD PERFORMANCE PARTS © Ford Motor Company 2020

E. REPEAT TO OTHER SIDE OF VEHICLE.

39. **GREASE** THE NEW SHACKLE BUSHINGS (INSIDE, OUT AND THE FACE OF THE BUSHINGS). **GREASE** THE STEEL SLEEVES AND THE INSIDE OF THE LOWER SHACKLE TUBES. INSTALL THE **GREASED** SHACKLE BUSHINGS AND SLEEVES INTO THE **GREASED** LOWER SHACKLE TUBES. (HIGH TEMP WHEEL BEARING GREASE WORKS FINE). **NOTE:** IF YOU DO NOT GREASE THESE POINTS **BEFORE** THE SHACKLE IS ASSEMBLED THE BUSHINGS WILL SQUEAK.

40. DROP SHACKLE INSTALLATION.



REAR SHACKLE INSTALLED WITH OPEN END TOWARD THE FRONT OF VEHICLE.

GREASE THE BUSHINGS AND THE FRAME TO BUSHING AREA.

A. INSTALL THE NEW DROP SHACKLE OVER THE REAR LEAF SPRING EYE WITH THE **OPEN** END OF THE SHACKLE TOWARD THE FRONT.

B. INSTALL THE STOCK UPPER BOLT (WITH THE HEAD INBOARD) THROUGH THE NEW SHACKLE AND THE STOCK LEAF SPRING, INSTALL THE STOCK NUT AND JUST SNUG AT THIS TIME.

C. REPEAT TO THE OTHER SIDE.

41. LOWER THE REAR AXLE SLIGHTLY AND LINE UP BOTH LOWER SHACKLE TO FRAME BOLT HOLES.

A. INSTALL THE STOCK LOWER SHACKLE BOLT (WITH THE HEAD INBOARD) THROUGH THE FRAME AND SHACKLE.

B. INSTALL THE STOCK LOWER SHACKLE NUT AND JUST SNUG AT THIS TIME.

C. REPEAT TO THE OTHER SIDE OF VEHICLE.

NO PART OF THIS DOCUMENT MAY BE REPRODUCED WITHOUT PRIOR AGREEMENT AND WRITTEN PERMISSION OF FORD PERFORMANCE PARTS © Ford Motor Company 2020

42. WITH THE JACK STANDS SECURE UNDER THE VEHICLES FRAME, JACK THE REAR AXLE UP TO RIDE HEIGHT AND TORQUE THE SHACKLE HARDWARE TO THE TORQUE SPEC OF 173Ft/lbs (235Nm)

43. REINSTALL THE REAR SHOCK LOWER MOUNT TO THE VEHICLE USING THE STOCK HARDWARE AND TORQUE TO SHOCK HARDWARE TO THE TORQUE SPEC OF 66Ft/lbs (90Nm)

44. REINSTALL THE REAR TIRE AND WHEEL ASSEMBLY. TORQUE THE LUG NUTS TO SPEC OF 150Ft/lbs. CHECK THE CLEARANCE BETWEEN THE REAR AXLE AND ALL REAR COMPONENTS. ADJUST IF NECESSARY.

45. TRANSMISSION SPACER INSTALLATION

A. LOCATE AND REMOVE THE TWO FACTORY REAR TRANSMISSION MOUNTING NUTS (THE NUTS THAT ARE UNDER THE TRANSMISSION CROSSMEMBER).

B. JACK THE TRANSMISSION UP APPROX. 5/16" AND SLIDE THE SPACER OVER THE STUDS BETWEEN THE TOP OF THE CROSSMEMBER AND THE BOTTOM OF TRANSMISSION MOUNT AND INSTALL THE STOCK NUTS JUST SNUG.

C. CENTER THE TRANSMISSION SIDE TO SIDE, LOWER THE JACK AND TORQUE THE TRANSMISSION MOUNT NUTS TO SPEC OF 85Ft/lbs (115Nm)



TRANSMISSION MOUNT

SUPPLIED TRANSMISSION SPACER BEING INSTALLED BETWEEN THE TOP OF THE CROSS MEMBER AND THE BOTTOM OF THE TRANS. MOUNT.

CROSSMEMBER

46. JACK UP THE REAR OF VEHICLE REMOVE SAFETY STANDS AND LOWER VEHICLE.

47. GO BACK AND CHECK THAT ALL INSTALLATION STEPS HAVE BEEN COMPLETED. CHECK THE TORQUE OF ALL NUTS AND BOLTS AFFECTED BY THIS PROCEDURE. RECHECK ALL NUTS AND BOLTS FOR TIGHTNESS AFTER THE FIRST 300 MILES AND AT EVERY ROUTINE SERVICE INSPECTION.

48. MAKE SURE THERE ARE NO CLEARANCE PROBLEMS. ROTATE THE STEERING LOCK TO LOCK UNDER FULL WEIGHT OF THE VEHICLE AND FULL SUSPENSION TRAVEL.

Ford Factory Shop Manual purchase options www.motorcraftservice.com



FORD PERFORMANCE

M-F150-FPS7 (Classic)
F-150 (4X4 Regular Cab & 4X2 Regular Cab)
FP700S Package

NO PART OF THIS DOCUMENT MAY BE REPRODUCED WITHOUT PRIOR AGREEMENT AND WRITTEN PERMISSION OF
FORD PERFORMANCE PARTS © Ford Motor Company 2020

49. MAKE SURE TO INSTALL THE SUPPLIED WARNING DECAL FOLLOWING THE INSTRUCTIONS INCLUDED WITH THE WARNING INFORMATION SHEET.
50. MAKE SURE TO KEEP THESE INSTRUCTIONS WITH THE VEHICLE.
51. READJUST THE HEADLIGHTS TO THE PROPER SETTINGS.
52. ROAD TEST THE VEHICLE.
53. THE VEHICLE NEEDS TO HAVE A FRONT END ALIGNMENT PERFORMED IMMEDIATELY AFTER THE INSTALLATION OF THIS KIT IS COMPLETE. THE FACTORY ADJUSTING BOLTS WILL NEED TO BE SET TO THE FACTORY SPECIFICATIONS.

WARNING: AGAIN CHECK TIRE AND WHEEL CLEARANCE BEFORE MOVING VEHICLE. ALSO CHECK CLEARANCE IF INSTALLING NEW TIRES AND/OR WHEELS.

NOTE: INSTALLATION OF WHEELS WITH BACKSPACING OTHER THAN STOCK MAY CHANGE THE VEHICLE HEIGHT AND ALSO EFFECT THE FRONT END ALIGNMENT.

Ford Factory Shop Manual purchase options www.motorcraftservice.com



M-F150-FPS7 (Classic)
F-150 (4X4 Regular Cab & 4X2 Regular Cab)
FP700S Package

NO PART OF THIS DOCUMENT MAY BE REPRODUCED WITHOUT PRIOR AGREEMENT AND WRITTEN PERMISSION OF
FORD PERFORMANCE PARTS © Ford Motor Company 2020

11. Rear Lowering Kit

WARNING

MODIFYING AN ORIGINAL EQUIPPED VEHICLE WILL RESULT IN A VEHICLE HANDLING DIFFERENTLY. ALL TYPES OF SUSPENSION MODIFICATIONS WILL AFFECT REACTION, RIDE, HANDLING AND WEAR AND TEAR RATE OF A VEHICLE AND ITS COMPONENTS. ABRUPT MANEUVERS, SHARP AND SUDDEN TURNS AND WEATHER CONDITIONS WILL INCREASE THE VEHICLE'S SUSCEPTIBILITY FOR LOSS OF CONTROL. DEATH AND SERIOUS INJURY COULD BE THE RESULT IF YOU FAIL TO OPERATE A MODIFIED VEHICLE SAFELY. KNOW AND FOLLOW THE LAWS OF THE STATES.

READ INSTRUCTIONS COMPLETELY THROUGH BEFORE STARTING.

FAILURE TO ADHERE TO THE INSTRUCTIONS WILL VOID ANY GROUND FORCE WARRANTY
IT IS RECOMMENDED THAT INSTALLATION BE DONE BY A QUALIFIED MECHANIC.

REPLACE ALL STOCK PARTS THAT ARE DAMAGED OR WORN.

INTERMIXING OF PARTS IS NOT RECOMMENDED AND WILL VOID THE WARRANTY.

ALWAYS WEAR EYE PROTECTION.

ALWAYS USE PROPERLY RATED SAFETY STANDS WHENEVER A PROCEDURE REQUIRES
YOU TO BE UNDER A VEHICLE. KNOW AND FOLLOW ALL SAFE WORK PRACTICES TO AVOID
SERIOUS INJURY OR DEATH.

CHECK TO SEE THAT ALL PARTS LISTED ARE INCLUDED.

- 1-INSTRUCTION SHEET
- 1-GROUND FORCE WARNING DECAL
- 2-SHACKLES
- 2-FRONT COIL SPRINGS
- 2-REAR AXLE SHIMS
- 4-UBOLTS
- 8-WASHERS
- 8-UBOLT NUTS
- 4-URETHANE SHACKLE BUSHINGS
- 2-SHACKLE SLEEVES
- 2-GREASE FITTINGS

Ford Factory Shop Manual purchase options www.motorcraftservice.com

NO PART OF THIS DOCUMENT MAY BE REPRODUCED WITHOUT PRIOR AGREEMENT AND WRITTEN PERMISSION OF FORD PERFORMANCE PARTS © Ford Motor Company 2020

NOTE: AMOUNT OF DROP APPROXIMATE DUE TO FACTORY OPTIONS.

MEASURE AND DOCUMENT THE VEHICLE HEIGHT FROM FLOOR TO FENDER LIP.

LF _____ RF _____ LR _____ RR _____

1. BEFORE GETTING UNDER VEHICLE, REMOVE THE KEYS FROM THE IGNITION. DISCONNECT THE NEGATIVE BATTERY TERMINAL FROM THE BATTERY. DO NOT MOVE THE STEERING OR TIE RODS LEFT OR RIGHT WHILE DOING THIS INSTALLATION AS MISALIGNMENT OF THE ELECTRONIC STEERING SYSTEM MAY RESULT. JACK THE FRONT OF VEHICLE UP AND PLACE STANDS UNDER THE FRAME RAILS. LOWER THE VEHICLE ONTO JACK STANDS AND MAKE SURE STANDS ARE SECURELY HOLDING THE VEHICLE.
2. REMOVE TIRE AND WHEEL ASSEMBLY.
3. REMOVE THE UPPER CONNECTING LINK HARDWARE FROM THE SWAY BAR ON BOTH SIDES OF VEHICLE, SAVE HARDWARE.



UPPER SWAY
BAR LINK
HARDWARE

SPLASH
SHIELD



4. LOCATE THE SPLASH SHIELD BEHIND THE LOWER CONTROL ARM REAR BOLTS AND REMOVE THE FOUR BOLTS HOLDING THE SPLASH SHIELD TO THE FRAME BRACKETS (THIS WILL ALLOW YOU TO LOOSEN AND REMOVE THE REAR SET OF LOWER CONTROL ARM BOLTS).
5. LOOSEN THE OUTER TIE ROD NUT, TAP ON THE SPINDLE WITH A MALLET TO POP THE TIE ROD JOINT LOOSE FROM THE SPINDLE. REMOVE THE OUTER TIE ROD FROM THE SPINDLE, SAVE NUT, REPEAT TO THE OTHER SIDE OF VEHICLE.

NO PART OF THIS DOCUMENT MAY BE REPRODUCED WITHOUT PRIOR AGREEMENT AND WRITTEN PERMISSION OF FORD PERFORMANCE PARTS © Ford Motor Company 2020

6. THE LOWER CONTROL ARM FRAME MOUNTS HAVE FACTORY ALIGNMENT SLOTS AND MUST BE MARKED BEFORE LOOSING. THIS PROCEDURE WILL AID IN ADJUSTING THESE BOLTS BACK TO THE CORRECT LOCATION DURING FINAL ASSEMBLY. REFER TO THE PHOTO BELOW

A. USING A PAINT STICK MARK ALL FOUR LOWER CONTROL ARM MOUNTING BOLT LOCATIONS.

B. LOOSEN BUT DO NOT REMOVE THE FOUR LOWER CONTROL ARM TO FRAME MOUNT BOLTS. THIS NEEDS TO BE DONE SO THAT THE LOWER CONTROL ARM WILL SWING DOWN FAR ENOUGH TO BE ABLE TO REMOVE THE STRUT ASSEMBLY FROM THE VEHICLE. SUPPORT THE LOWER CONTROL ARM.



LOWER CONTROL ARM TO FRAME MOUNTING HARDWARE.

PAINT STICK MARK SHOWING FACTORY HARDWARE LOCATION.

7. MARK THE UPPER AND LOWER STRUT MOUNTS SO THAT WHEN YOU INSTALL THE NEW COIL SPRINGS YOU WILL BE ABLE TO ALIGN THE UPPER AND LOWER STRUT MOUNTS IN THEIR CORRECT LOCATION. MARK THE STRUT ASSEMBLY LEFT AND RIGHT.



UPPER AND LOWER STRUT INDEX MARKS



8. LOOSEN AND REMOVE THE TWO LOWER STRUT MOUNTING NUTS LOCATED UNDER THE LOWER CONTROL ARM, SAVE HARDWARE.



LOWER STRUT MOUNTING HARDWARE LOCATION.

WARNING: THE COIL SPRING ASSEMBLY IS UNDER PRESSURE, DO NOT REMOVE THE CENTER UPPER STRUT ROD NUT.

NO PART OF THIS DOCUMENT MAY BE REPRODUCED WITHOUT PRIOR AGREEMENT AND WRITTEN PERMISSION OF FORD PERFORMANCE PARTS © Ford Motor Company 2020

9. LOOSEN THE UPPER THREE OUTER NUTS ATTACHING THE STRUT ASSEMBLY TO THE VEHICLE FRAME.
10. SUPPORT THE LOWER CONTROL ARM NOTE THE DIRECTION OF THE MOUNTING HARDWARE THAT ATTACHES THE LOWER CONTROL ARM A TO FRAME MOUNTS. REMOVE THE LOWER CONTROL ARM TO FRAME HARDWARE (REFER TO PHOTOS BELOW).
11. LOWER THE JACK SLIGHTLY UNDER THE LOWER CONTROL ARM, REMOVE THE UPPER OUTER THREE STRUT TO FRAME NUTS AND REMOVE THE STRUT ASSEMBLY FROM THE VEHICLE. SAVE HARDWARE.

DRIVERS SIDE FRONT SHOWN WITH STRUT REMOVED

LOWER CONTROL ARM BEING LOWERED AWAY FROM LOWER STRUT MOUNTING STUDS



12. REPEAT STRUT REMOVAL PROCEDURE TO OTHER SIDE OF VEHICLE.
13. NEW COIL SPRING INSTALLATION PROCEDURE.

Ford Factory Shop Manual purchase options www.motorcraftservice.com

NO PART OF THIS DOCUMENT MAY BE REPRODUCED WITHOUT PRIOR AGREEMENT AND WRITTEN PERMISSION OF FORD PERFORMANCE PARTS © Ford Motor Company 2020

14. COIL SPRING INDEXING.

E. AGAIN IT IS VERY IMPORTANT TO PLACE INDEX MARKS ON THE UPPER AND LOWER STRUT SPRING MOUNTS SO THAT ONCE THE STRUT IS DISASSEMBLED AND REASSEMBLED YOU CAN ALIGN THE UPPER AND LOWER MOUNTS IN THE CORRECT LOCATION.

15. COMPRESS THE STRUT ASSEMBLY STOCK COIL SPRING USING A STRUT/COILOVER COMPRESSOR. FOLLOW THE STRUT/COILOVER COMPRESSOR INSTRUCTIONS.



UPPER STRUT CAP INDEX MARK

STRUT ASSEMBLY COMPRESSED IN A STRUT COMPRESSOR.

LOWER STRUT MOUNT INDEX MARK

16. ONCE THE SPRING IS COMPRESSED REMOVE THE CENTER UPPER STRUT ROD NUT WHILE HOLDING THE STRUT SHAFT FROM SPINNING INSIDE OF THE STRUT. SAVE HARDWARE

- A. REMOVE THE UPPER STRUT MOUNT FROM THE STRUT.
- B. REMOVE THE UPPER RUBBER SPRING SEAT FROM THE STRUT.
- C. REMOVE THE STRUT FROM THE COIL SPRING.
- D. REMOVE THE STOCK COIL FROM THE STRUT/COILOVER COMPRESSOR.

17. COIL TO STRUT SHOCK INSTALLATION PROCEDURE. FOLLOW THE STRUT/COILOVER COMPRESSOR INSTRUCTIONS.

WARNING: THE COIL IS UNDER PRESSURE. EXTREME CARE MUST BE TAKEN WHEN AND INSTALLING THE COILS TO AVOID INJURY.

- A. INSTALL THE NEW GROUND FORCE COIL INTO THE COILOVER/STRUT COMPRESSOR (SMALL END GOES DOWN) AND COMPRESS THE NEW COIL.
- B. INSTALL THE STOCK STRUT UP THROUGH THE NEW DROP COIL.
- C. INSTALL THE STOCK UPPER RUBBER ISOLATOR AND TOP HAT ONTO THE TOP OF THE COIL. MAKE SURE THAT THE UPPER COIL IS LOCATED AGAINST THE UPPER COIL STOP AND THAT THE RUBBER ISOLATOR IS LOCATED CORRECTLY IN THE SPRING SEAT. SEE THE PHOTO BELOW.

Ford Factory Shop Manual purchase options www.motorcraftservice.com



FORD PERFORMANCE

**M-F150-FPS7 (Classic)
F-150 (4X4 Regular Cab & 4X2 Regular Cab)
FP700S Package**

NO PART OF THIS DOCUMENT MAY BE REPRODUCED WITHOUT PRIOR AGREEMENT AND WRITTEN PERMISSION OF FORD PERFORMANCE PARTS © Ford Motor Company 2020

D. LOCATE THE UPPER SPRING SEAT INDEX MARK AND ALIGN IT WITH THE WITH THE LOWER SPRING SEAT INDEX MARK (INDEX MARKS FROM STEP 7).

E. INSTALL THE UPPER STRUT CENTER RETAINING NUT TO THE STRUT SHAFT AND TORQUE THE STRUT SHAFT RETAINING NUT TO SPEC OF 41 Ft/lbs (55Nm)

F. ONCE THAT YOU ARE SURE THE COIL IS LOCATED CORRECTLY ON THE STRUT REMOVE THE STRUT/COIL ASSEMBLY FROM THE COMPRESSOR. FOLLOW THE STRUT COMPRESSOR INSTRUCTIONS.

G. REPEAT COIL INSTALLATION TO THE OTHER STRUT.

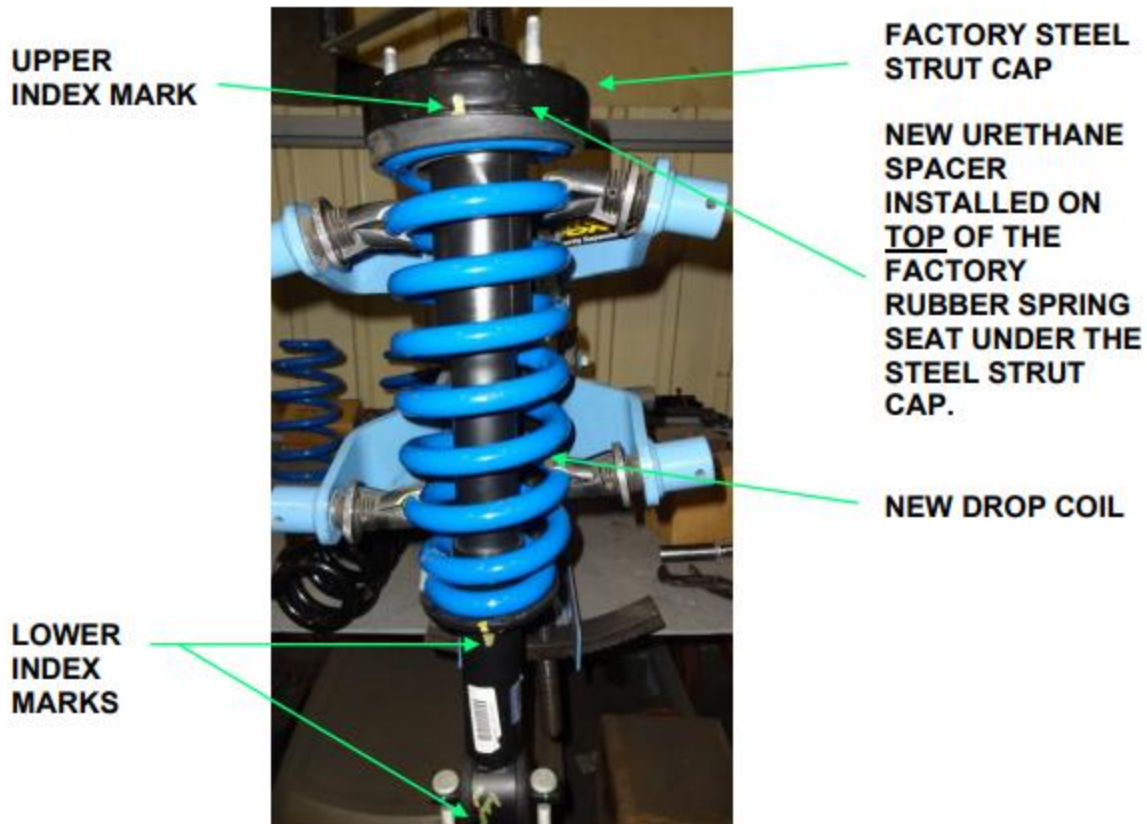

Ford Factory Shop Manual purchase options www.motorcraftservice.com



M-F150-FPS7 (Classic)
F-150 (4X4 Regular Cab & 4X2 Regular Cab)
FP700S Package

NO PART OF THIS DOCUMENT MAY BE REPRODUCED WITHOUT PRIOR AGREEMENT AND WRITTEN PERMISSION OF
FORD PERFORMANCE PARTS © Ford Motor Company 2020

18. STRUT TO VEHICLE INSTALLATION.
- A. INSTALL THE STRUT ASSEMBLY UP INTO THE STOCK LOCATION.
 - B. ALIGN AND INSTALL THE THREE STUDS UP INTO THE THREE HOLES IN THE FRAME UPPER MOUNT.
 - C. INSTALL THE FACTORY THREE UPPER STRUT LOCKNUTS (JUST START THE NUTS AS THE UPPER STRUT MOUNT WILL NEED TO MOVE SOME WHEN THE LOWER STRUT STUDS ARE BEING LINED UP WITH THE LOWER CONTROL ARM).
 - D. JACK UP THE LOWER CONTROL ARM AND LINE UP THE LOWER STRUT MOUNTING STUDS INTO THE LOWER CONTROL ARM AND JUST START THE FACTORY LOWER STRUT RETAINING NUTS.
 - E. CONTINUE TO JACK UP THE LOWER CONTROL ARM LINING UP THE CONTROL ARM INTO THE FRAME MOUNTING POCKETS, REINSTALL THE FACTORY LOWER CONTROL ARM TO FRAME MOUNTING HARDWARE IN THE SAME DIRECTION AS REMOVED JUST START THE NUTS.
 - F. INSTALL THE CONNECTING LINK UP INTO THE SWAY BAR AND JUST START THE FACTORY RETAINING NUT.
 - G. REPEAT STRUT INSTALLATION PROCEDURE TO THE OTHER SIDE OF VEHICLE.
 - I. TORQUE THE LOWER STRUT MOUNTING HARDWARE TO THE TORQUE SPEC OF 66FT/LBs.
19. REPOSITION THE JACK OUT TOWARD THE SPINDLE SIDE OF THE LOWER CONTROL ARM AND JACK THE SUSPENSION UP TO RIDE HEIGHT (MAKE SURE YOUR SAFETY STANDS ARE SECURE UNDER THE VEHICLE). WITH THE HELP OF AN ASSISTANT LINE UP THE LOWER CONTROL ARM MOUNTING HARDWARE TO THE MARKS MADE IN STEP NO 6 AND TORQUE THE LOWER CONTROL ARM TO FRAME MOUNTING BOLTS TO THE TORQUE SPEC OF 258ft/lbs (350Nm). REPEAT TO THE OTHER SIDE OF VEHICLE.
20. TORQUE THE UPPER THREE STRUT NUTS TO THE TORQUE SPEC OF 52FT/lbs (70Nm)
21. WITH THE STRUT AND LOWER CONTROL ARM NOW TIGHTENED TO SPEC LOWER THE JACK UNDER THE LOWER CONTROL ARM UNTIL THE SUSPENSION IS FREE HANGING (4X4 MODELS).
- A. WITH THE STEERING TIE RODS STILL DISCONNECTED TURN THE STEERING KNUCKLES FROM COMPLETE LEFT LOCK TO COMPLETE RIGHT LOCK BY HAND AND VERIFY THAT YOU HAVE CLEARANCE BETWEEN THE LOWER STRUT MOUNT AND THE OUTER CV BOOT AS SHOWN BELOW. THIS SYSTEM WAS DESIGNED TO HAVE CLEARANCE WITH FACTORY CV BOOTS.

Ford Factory Shop Manual purchase options www.motorcraftservice.com



FORD PERFORMANCE

M-F150-FPS7 (Classic)
F-150 (4X4 Regular Cab & 4X2 Regular Cab)
FP700S Package

NO PART OF THIS DOCUMENT MAY BE REPRODUCED WITHOUT PRIOR AGREEMENT AND WRITTEN PERMISSION OF FORD PERFORMANCE PARTS © Ford Motor Company 2020



**4X4 MODELS
CLEARANCE BEING
CHECKED BETWEEN THE
OUTER CV BOOT AND
THE LOWER STRUT
MOUNT. MAINTAIN A
MINIMUM OF 1/8" AT THE
CLOSEST POINT WITH
THE SUSPENSION
HANGING IN THE FULL
DROOP POSITION.**

23. REINSTALL THE TIE RODS TO THE SPINDLES AND TORQUE TO THE SPEC OF 66Ft/lbs (90Nm)
24. TORQUE THE UPPER CONNECTING LINK NUTS TO SPEC OF 150Ft/lbs (150Nm) ON BOTH SIDES OF THE VEHICLE.
25. REINSTALL THE SPLASH SHIELD INTO THE FACTORY POSITION AND INSTALL THE FACTORY HARDWARE AND TORQUE TO SPEC.
26. MAKE SURE ALL FASTENERS AFFECTED BY THIS PROCEDURE ARE TORQUED TO SPEC.
27. REINSTALL TIRE AND WHEEL ASSEMBLY AND TORQUE TO SPEC.
28. CHECK AND MAKE SURE THAT ALL INSTALLATION STEPS HAVE BEEN COMPLETED. CHECK ALL NUTS AND BOLTS FOR TORQUE AFTER THE FIRST 300 MILES.
29. JACK THE VEHICLE UP AND REMOVE STANDS, THEN LET THE VEHICLE DOWN AND RECONNECT THE NEGATIVE BATTERY TERMINAL ON THE BATTERY.
30. MAKE SURE THERE ARE NO CLEARANCE PROBLEMS. ROTATE THE STEERING LOCK TO LOCK UNDER FULL WEIGHT OF THE VEHICLE AND FULL SUSPENSION TRAVEL.

Ford Factory Shop Manual purchase options www.motorcraftservice.com

NO PART OF THIS DOCUMENT MAY BE REPRODUCED WITHOUT PRIOR AGREEMENT AND WRITTEN PERMISSION OF FORD PERFORMANCE PARTS © Ford Motor Company 2020

REAR INSTALL

NOTE: AMOUNT OF DROP APPROXIMATE DUE TO FACTORY OPTIONS AND OR AFTERMARKET OPTIONS.

31. JACK UP THE REAR OF THE VEHICLE AND PLACE JACK STANDS UNDER THE FRAME RAILS. LOWER THE VEHICLE ONTO THE JACK STANDS AND MAKE SURE THE STANDS ARE SECURELY HOLDING THE VEHICLE. SUPPORT THE REAR AXLE WITH A FLOOR JACK AND SMALL JACK STANDS.

32. REMOVE THE REAR TIRE WHEEL ASSEMBLY.

WARNING: THE LEAF SPRINGS ARE UNDER PRESSURE. EXTREME CARE MUST BE TAKEN WHEN WORKING WITH THE SPRINGS TO AVOID INJURY.

33. SUPPORT THE REAR AXLE.

34. REMOVE THE STOCK REAR SHOCKS FROM THE LOWER MOUNTS, SAVE HARDWARE.

35. REMOVE THE U-BOLTS FROM ONE SIDE AND LET THE REAR AXLE DOWN UNTIL THE FACTORY BLOCK CAN BE REMOVED (IF EQUIPPED, BLOCK NOT PRESENT ON SOME 4X2 MODELS)

A. REMOVE THE FACTORY BLOCK AND DISCARD.

36. INSTALL THE WEDGE ON TOP OF THE AXLE WITH THE THICKER END OF THE WEDGE TOWARD THE REAR OF THE VEHICLE.



WEDGE INSTALLED WITH THE THICK END TOWARD THE REAR OF THE VEHICLE.

NEW U-BOLTS

PLASTIC RETAINING CLIPS



FORD PERFORMANCE

M-F150-FPS7 (Classic)
F-150 (4X4 Regular Cab & 4X2 Regular Cab)
FP700S Package

NO PART OF THIS DOCUMENT MAY BE REPRODUCED WITHOUT PRIOR AGREEMENT AND WRITTEN PERMISSION OF
FORD PERFORMANCE PARTS © Ford Motor Company 2020

37. JACK THE AXLE UP AND LINE UP THE CENTER PIN HEADS THROUGH THE WEDGES AND INTO THE AXLE PIN HOLES.
- A. INSTALL THE NEW U-BOLTS AND U-BOLT HARDWARE.
 - F. SNUG THE U-BOLT NUTS MAKING SURE THE CENTER PIN HEADS STAY IN THE AXLE CENTER PIN HOLES.
 - G. REPEAT THE BLOCK REMOVAL AND WEDGE INSTALLATION TO THE OTHER SIDE OF THE VEHICLE.
 - H. TORQUE THE REAR LEAF SPRING IN A CROSS PATTERN IN THE FOLLOWING 4 STAGES
 - Stage 1: 30 lb.ft (40 Nm)
 - Stage 2: 59 lb.ft (80 Nm)
 - Stage 3: 89 lb.ft (120 Nm)
 - Stage 4: 111 lb.ft (150 Nm)
 - I. IF EQUIPPED REATTACH THE PLASTIC RETAINING CLIPS OVER THE U-BOLTS.

WARNING: THE LEAF SPRING ARE UNDER PRESSURE. EXTREME CARE MUST BE TAKEN WHEN REMOVING AND INSTALLING THE SHACKLES TO AVOID INJURY.

38. REAR SHACKLE REMOVAL. MAKE SURE THE JACK STANDS ARE SECURE UNDER THE VEHICLE FRAME.
- A. NOTE THE STOCK SHACKLE HARDWARE LOCATION AND DIRECTION OF THE BOLT HEADS.
 - B. LOOSEN THE LOWER SHACKLE TO FRAME BOLT.
 - C. LOOSEN THE UPPER SHACKLE TO SPRING EYE BOLT.

Ford Factory Shop Manual purchase options www.motorcraftservice.com

NO PART OF THIS DOCUMENT MAY BE REPRODUCED WITHOUT PRIOR AGREEMENT AND WRITTEN PERMISSION OF FORD PERFORMANCE PARTS © Ford Motor Company 2020

D. WITH THE REAR AXLE SUPPORTED REMOVE THE LOWER SHACKLE BOLTS, SAVE ALL HARDWARE AS IT WILL BE REUSED. PLACE SOME DUCT TAPE ON THE REAR OF THE CROSSMEMBER AS SHOWN BELOW. JACK THE AXLE UP UNTIL THE UPPER SHACKLE BOLTS CAN BE REMOVED OVER THE TOP OF THE FRAME RAIL. THE LEAF SPRING REAR EYE WILL SLIDE UP **BEHIND** THE REAR BED CROSS MEMBER AS SHOWN BELOW. MAKE SURE THE VEHICLE IS SECURE ON THE STANDS AS YOU WILL HAVE TO PUT SOME PRESSURE ON THE JACK TO GET THE SHACKLE HIGH ENOUGH TO GET THE BOLTS TO SLIDE OUT OVER THE FRAME RAILS REMOVE THE UPPER SHACKLE BOLT AND REMOVE THE SHACKLE FROM THE VEHICLE.



**UPPER SHACKLE
BOLT BEING
REMOVED OVER THE
TOP OF THE FRAME**

E. REPEAT TO OTHER SIDE OF VEHICLE.

NO PART OF THIS DOCUMENT MAY BE REPRODUCED WITHOUT PRIOR AGREEMENT AND WRITTEN PERMISSION OF FORD PERFORMANCE PARTS © Ford Motor Company 2020

39. **GREASE** THE NEW SHACKLE BUSHINGS (INSIDE, OUT AND THE FACE OF THE BUSHINGS). **GREASE** THE STEEL SLEEVES AND THE INSIDE OF THE LOWER SHACKLE TUBES. INSTALL THE **GREASED** SHACKLE BUSHINGS AND SLEEVES INTO THE **GREASED** LOWER SHACKLE TUBES. (HIGH TEMP WHEEL BEARING GREASE WORKS FINE). **NOTE:** IF YOU DO NOT GREASE THESE POINTS **BEFORE** THE SHACKLE IS ASSEMBLED THE BUSHINGS WILL SQUEAK.

40. DROP SHACKLE INSTALLATION.



REAR SHACKLE INSTALLED WITH OPEN END TOWARD THE FRONT OF VEHICLE.

GREASE THE BUSHINGS AND THE FRAME TO BUSHING AREA.

A. INSTALL THE NEW DROP SHACKLE OVER THE REAR LEAF SPRING EYE WITH THE **OPEN** END OF THE SHACKLE TOWARD THE FRONT.

B. INSTALL THE STOCK UPPER BOLT (WITH THE HEAD INBOARD) THROUGH THE NEW SHACKLE AND THE STOCK LEAF SPRING, INSTALL THE STOCK NUT AND JUST SNUG AT THIS TIME.

C. REPEAT TO THE OTHER SIDE.

41. LOWER THE REAR AXLE SLIGHTLY AND LINE UP BOTH LOWER SHACKLE TO FRAME BOLT HOLES.

A. INSTALL THE STOCK LOWER SHACKLE BOLT (WITH THE HEAD INBOARD) THROUGH THE FRAME AND SHACKLE.

B. INSTALL THE STOCK LOWER SHACKLE NUT AND JUST SNUG AT THIS TIME.

C. REPEAT TO THE OTHER SIDE OF VEHICLE.

42. WITH THE JACK STANDS SECURE UNDER THE VEHICLES FRAME, JACK THE REAR AXLE UP TO RIDE HEIGHT AND TORQUE THE SHACKLE HARDWARE TO THE TORQUE SPEC OF 173Ft/lbs (235Nm)

Ford Factory Shop Manual purchase options www.motorcraftservice.com

NO PART OF THIS DOCUMENT MAY BE REPRODUCED WITHOUT PRIOR AGREEMENT AND WRITTEN PERMISSION OF FORD PERFORMANCE PARTS © Ford Motor Company 2020

43. REINSTALL THE REAR SHOCK LOWER MOUNT TO THE VEHICLE USING THE STOCK HARDWARE AND TORQUE TO SHOCK HARDWARE TO THE TORQUE SPEC OF 66Ft/lbs (90Nm)

44. REINSTALL THE REAR TIRE AND WHEEL ASSEMBLY. TORQUE THE LUG NUTS TO SPEC. CHECK THE CLEARANCE BETWEEN THE REAR AXLE AND ALL REAR COMPONENTS. ADJUST IF NECESSARY.

45. TRANSMISSION SPACER INSTALLATION

A. LOCATE AND REMOVE THE TWO FACTORY REAR TRANSMISSION MOUNTING NUTS (THE NUTS THAT ARE UNDER THE TRANSMISSION CROSSMEMBER).

B. JACK THE TRANSMISSION UP APPROX. 5/16" AND SLIDE THE SPACER OVER THE STUDS BETWEEN THE TOP OF THE CROSSMEMBER AND THE BOTTOM OF TRANSMISSION MOUNT AND INSTALL THE STOCK NUTS JUST SNUG.

C. CENTER THE TRANSMISSION SIDE TO SIDE, LOWER THE JACK AND TORQUE THE TRANSMISSION MOUNT NUTS TO SPEC OF 85Ft/lbs (115Nm)



TRANSMISSION MOUNT

SUPPLIED TRANSMISSION SPACER BEING INSTALLED BETWEEN THE TOP OF THE CROSS MEMBER AND THE BOTTOM OF THE TRANS. MOUNT.

CROSSMEMBER

46. JACK UP THE REAR OF VEHICLE REMOVE SAFETY STANDS AND LOWER VEHICLE.

47. GO BACK AND CHECK THAT ALL INSTALLATION STEPS HAVE BEEN COMPLETED. CHECK THE TORQUE OF ALL NUTS AND BOLTS AFFECTED BY THIS PROCEDURE. RECHECK ALL NUTS AND BOLTS FOR TIGHTNESS AFTER THE FIRST 300 MILES AND AT EVERY ROUTINE SERVICE INSPECTION.

48. MAKE SURE THERE ARE NO CLEARANCE PROBLEMS. ROTATE THE STEERING LOCK TO LOCK UNDER FULL WEIGHT OF THE VEHICLE AND FULL SUSPENSION TRAVEL.



M-F150-FPS7 (Classic)
F-150 (4X4 Regular Cab & 4X2 Regular Cab)
FP700S Package

NO PART OF THIS DOCUMENT MAY BE REPRODUCED WITHOUT PRIOR AGREEMENT AND WRITTEN PERMISSION OF
FORD PERFORMANCE PARTS © Ford Motor Company 2020

49. MAKE SURE TO INSTALL THE SUPPLIED WARNING DECAL FOLLOWING THE INSTRUCTIONS INCLUDED WITH THE WARNING INFORMATION SHEET.
50. MAKE SURE TO KEEP THESE INSTRUCTIONS WITH THE VEHICLE.
51. READJUST THE HEADLIGHTS TO THE PROPER SETTINGS.
52. ROAD TEST THE VEHICLE.
53. THE VEHICLE NEEDS TO HAVE A FRONT END ALIGNMENT PERFORMED IMMEDIATELY AFTER THE INSTALLATION OF THIS KIT IS COMPLETE. THE FACTORY ADJUSTING BOLTS WILL NEED TO BE SET TO THE FACTORY SPECIFICATIONS.

WARNING: AGAIN CHECK TIRE AND WHEEL CLEARANCE BEFORE MOVING VEHICLE. ALSO CHECK CLEARANCE IF INSTALLING NEW TIRES AND/OR WHEELS.

NOTE: INSTALLATION OF WHEELS WITH BACKSPACING OTHER THAN STOCK MAY CHANGE THE VEHICLE HEIGHT AND ALSO EFFECT THE FRONT END ALIGNMENT.

Ford Factory Shop Manual purchase options www.motorcraftservice.com