



FORD PERFORMANCE

# M-8600-M50ALTA, M-8600-ALTC, M-8600-BALT Mustang 5.0L 2011 – 2023 Alternator Kits

NO PART OF THIS DOCUMENT MAY BE REPRODUCED WITHOUT PRIOR WRITTEN PERMISSION OF FORD PERFORMANCE PARTS  
© Ford Motor Company 2021

**PRIOR TO INSTALLATION READ THESE INSTRUCTION COMPETELY**  
**For questions, Call the FORD PERFORMANCE Techline 1-800-367-3788**

Please visit <https://www.performanceparts.ford.com> for warranty information

## M-8600-M50ALTA

Service Part #	Name	Qty
JR3Z-10346-D	200A Alternator	1
JR3Z-6B209-AA	Tensioner	1
CR3Z-8620-A	V-Belt	1
W709638-S439	Tensioner bolt	1
W715092-S437	Alternator bolt	1
AL3Z-8678-A	Idler Pulley	1
W707288-S437	Idler bolt	1
W715094-S437	Alternator bolt	1
W711953-S900	Batt Cable nut	1

## M-8600-M50ALTC

Service Part #	Name	Qty
JR3Z-10346-C	175A Alternator	1
JR3Z-6B209-AA	Tensioner	1
FR3Z-8620-B	V-Belt	1
W520414-S437	10mm nut	1
W709638-S439	Tensioner bolt	1
W712609-S437	Alternator stud	1
W715092-S437	Alternator bolt	1
AL3Z-8678-A	Idler Pulley	1
W716498-S437	Idler bolt	1
W711953-S900	Batt Cable nut	1

## M-8600-M50BALT

Service Part #	Name	Qty
CR3Z-10346-A	175A Alternator	1
JR3Z-6B209-AA	Tensioner	1
CR3Z-8620-A	V-Belt	1
W709638-S439	Tensioner bolt	1
W715092-S437	Alternator bolt	1
AL3Z-8678-A	Idler Pulley	1
W707288-S437	Idler bolt	1
W715094-S437	Alternator bolt	1
W711953-S900	Batt Cable nut	1

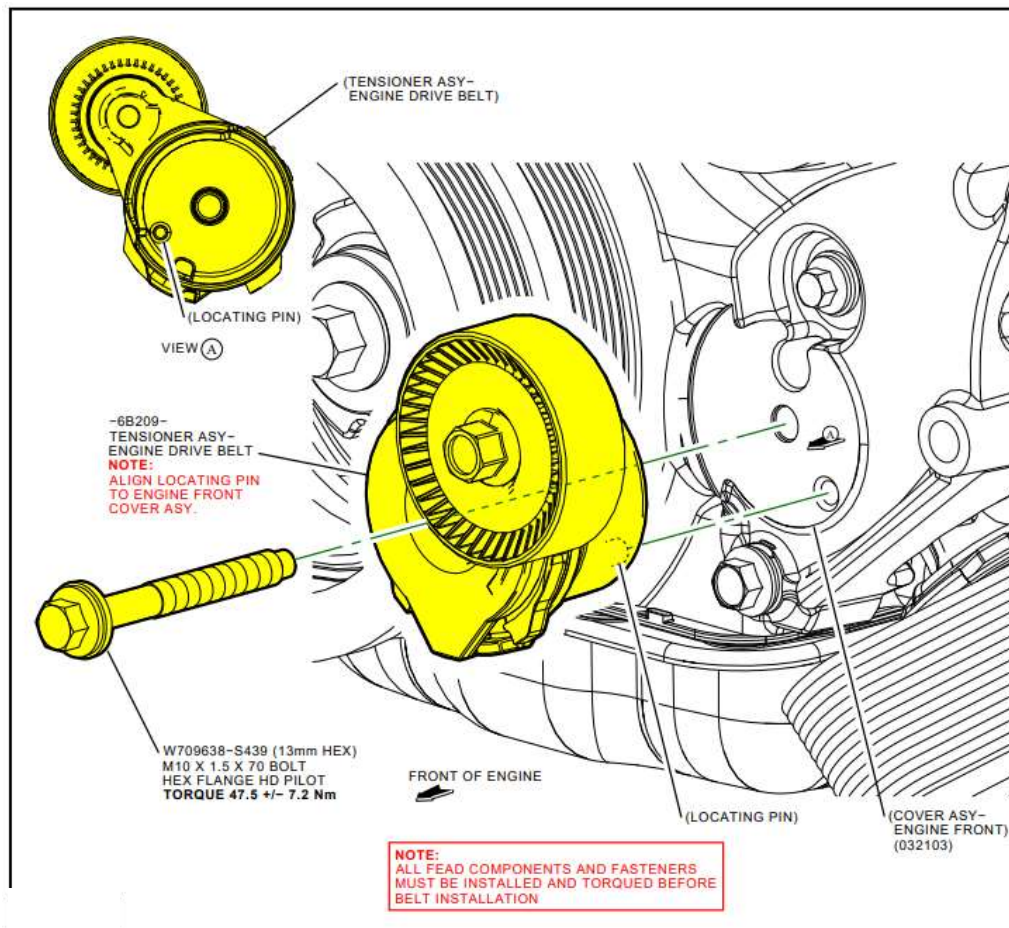

Ford Factory Shop Manual purchase options [www.motorcraftservice.com](http://www.motorcraftservice.com)



FORD PERFORMANCE

# M-8600-M50ALTA, M-8600-ALTC, M-8600-BALT Mustang 5.0L 2011 – 2023 Alternator Kits

NO PART OF THIS DOCUMENT MAY BE REPRODUCED WITHOUT PRIOR WRITTEN PERMISSION OF FORD PERFORMANCE PARTS  
© Ford Motor Company 2021

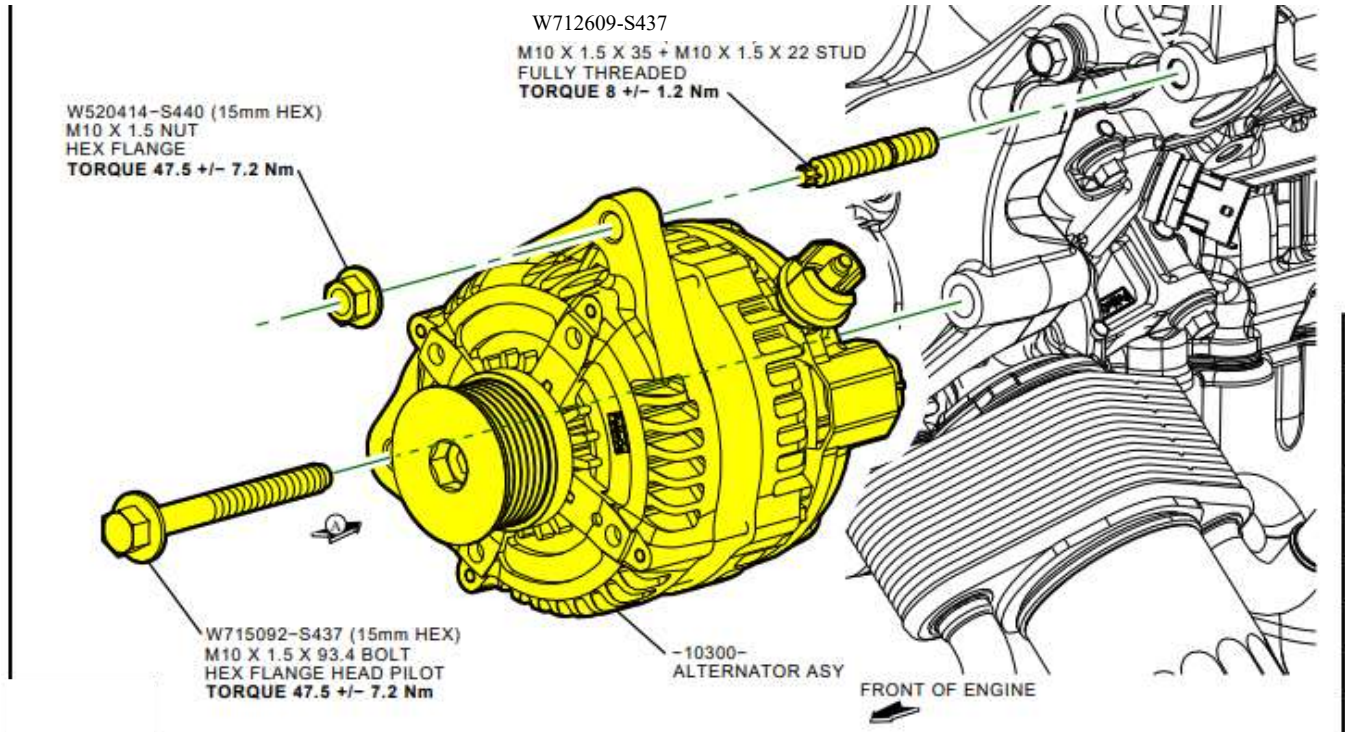

- For some kits, replace the nut (W520414) and stud (W712609) with bolt (W715094) and torque to 47.5 +/- 7.2Nm.
- Nut (W711953) is used for attachment of the battery cable to the Alternator.

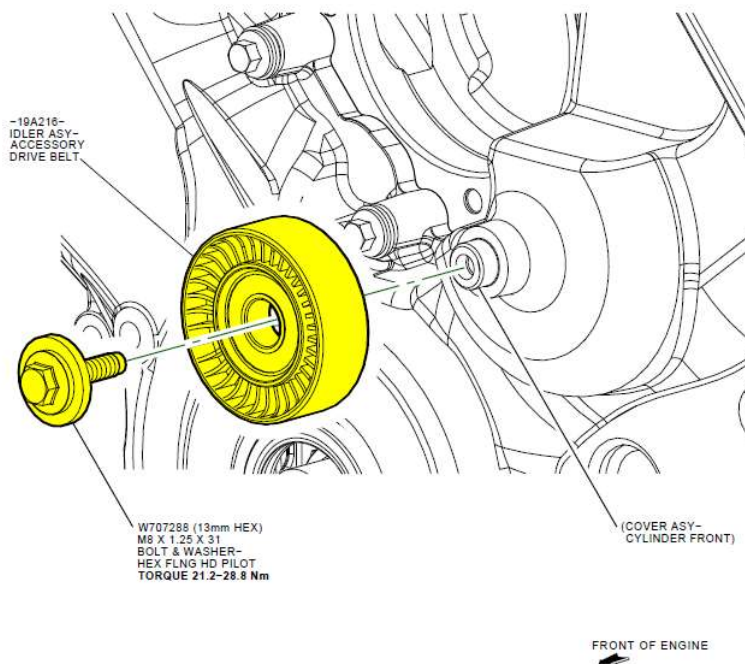

Ford Factory Shop Manual purchase options [www.motorcraftservice.com](http://www.motorcraftservice.com)





FORD PERFORMANCE

# M-8600-M50ALTA, M-8600-ALTC, M-8600-BALT Mustang 5.0L 2011 – 2023 Alternator Kits

NO PART OF THIS DOCUMENT MAY BE REPRODUCED WITHOUT PRIOR WRITTEN PERMISSION OF FORD PERFORMANCE PARTS  
© Ford Motor Company 2021

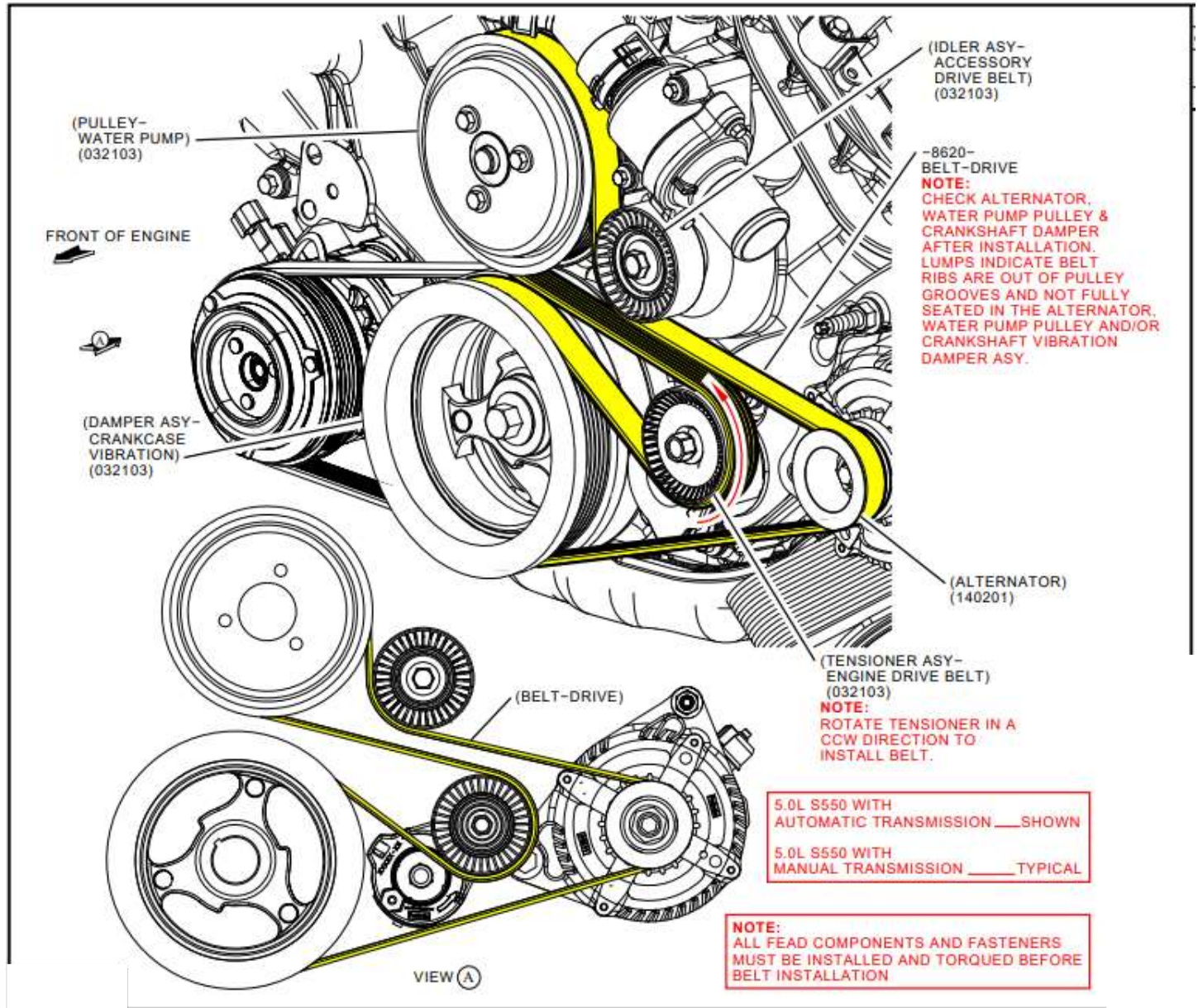

Ford Factory Shop Manual purchase options [www.motorcraftservice.com](http://www.motorcraftservice.com)