



M-6261-J351/K351 Cam Bearings INSTRUCTION SHEET

NO PART OF THIS DOCUMENT MAY BE REPRODUCED WITHOUT PRIOR AGREEMENT AND WRITTEN PERMISSION OF FORD RACING PERFORMANCE PARTS

Please contact the Tech "Hot Line" for the most current instruction information (586) 468-1356

!!! PLEASE READ THE FOLLOWING INSTRUCTIONS CAREFULLY PRIOR TO INSTALLATION !!!

INSTALLATION INSTRUCTIONS:

The #1 journal cam bearing may require modification to provide lubrication to the distributor pilot bushing and the cam thrust plate. A 0.187" diameter oil feed hold should be located as indicated in the sketch below. Also, a shallow groove should connect the cam bearing oil feed hole and the pilot bearing oil feed hole. If these features are missing, machine the bearing to add them as shown in the sketch.

Clock the oil holes for installation. Partial misalignment of the main oil feed hole can be fixed by drilling from the main bearing entrance.

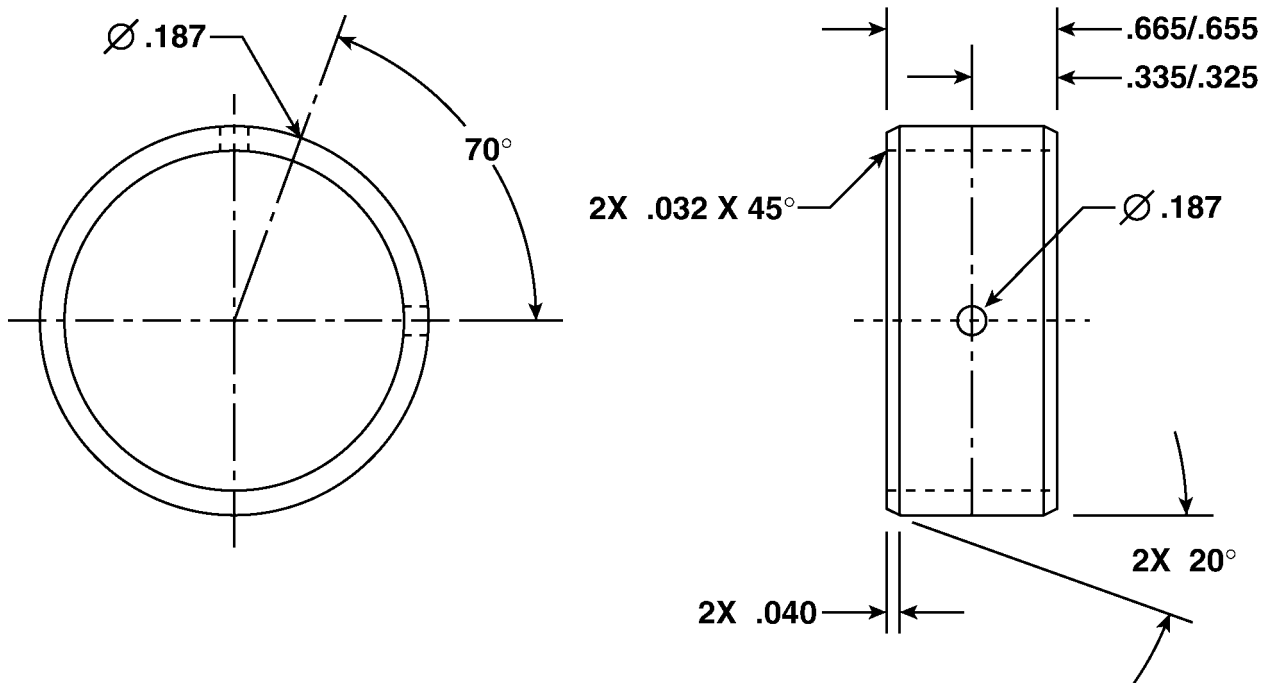

Tech "Hot Line" (586) 468-1356

Factory Ford shop manuals are available from Helm Publications, 1-800-782-4356