



## M-4209ADPT-A Speed-Dial (Speedometer Recalibration Tool) INSTRUCTION SHEET

NO PART OF THIS DOCUMENT MAY BE REPRODUCED WITHOUT PRIOR AGREEMENT AND WRITTEN PERMISSION OF FORD RACING PERFORMANCE PARTS

Please visit [www.fordracingparts.com](http://www.fordracingparts.com) for the most current instruction information

**!!! PLEASE READ ALL OF THE FOLLOWING INSTRUCTIONS CAREFULLY PRIOR TO INSTALLATION. AT ANY TIME YOU DO NOT UNDERSTAND THE INSTRUCTIONS, PLEASE CALL THE FORD RACING TECHLINE AT 1-800-367-3788 !!!**

### OVERVIEW:

Speed-Dial has been developed to be the simplest speedometer recalibration device on the market. It is designed to change the output signal of the Vehicle Speed Sensor (VSS) to compensate for axle ratio swaps or changes in tire size. Speed-Dial can increase the VSS signal up to 200% of the original signal, or decrease the signal by as much as 99%. Once the proper ratio has been determined, simply dial it into Speed-Dial, and the speedometer now reads correctly!

Speed-Dial has been successfully tested in the following applications:

- 1994-2010 Ford Mustang, Manual Transmission
- 1994-2004 Ford Mustang, Automatic Transmission

**NOTE:** Speed-Dial is capable of modifying the VSS signal on nearly any vehicle which uses a variable reluctance type VSS, but the calibration in the PCM of those other vehicles may not utilize this signal correctly. For example, on 2005-10 Mustangs equipped with Automatic transmissions, the speedometer signal can be corrected, but the PCM interprets the higher engine RPM as a torque converter that may be slipping, and may generate additional diagnostic faults.

**!!! CAUTION: JACK STANDS MUST BE USED ON A LEVEL SURFACE AND BE SECURELY SEATED. FAILURE TO DO SO MAY RESULT IN PERSONAL INJURY OR VEHICLE DAMAGE !!!**

### PARTS INCLUDED IN KIT:

- (1) Speed-Dial speedometer recalibration unit
- (1) Instruction sheet

### INSTALLATION INSTRUCTIONS:

**!!! PERFORM THE FOLLOWING WORK ON A COLD VEHICLE ONLY !!!**

For 1994 to 1998 Mustang, go to STEP 1

For 1999 to 2004 Mustang, go to STEP 8

For 2005 to 2010 Mustang, go to STEP 15

**NOTE:** Alternate instructions for mounting Speed-Dial under the hood are also included at the end of each installation procedure if applicable to the vehicle.

**Techline 1-800-367-3788**

Factory Ford shop manuals are available from Helm Publications, 1-800-782-4356



# M-4209ADPT-A Speed-Dial (Speedometer Recalibration Tool) INSTRUCTION SHEET

NO PART OF THIS DOCUMENT MAY BE REPRODUCED WITHOUT PRIOR AGREEMENT AND WRITTEN PERMISSION OF FORD RACING PERFORMANCE PARTS

**STEP 1:** 1994 to 1998 Mustang Installation Procedure

**STEP 2:** Identify and disconnect the VSS connector from the transmission.

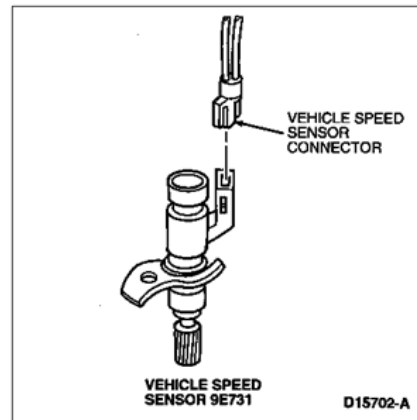
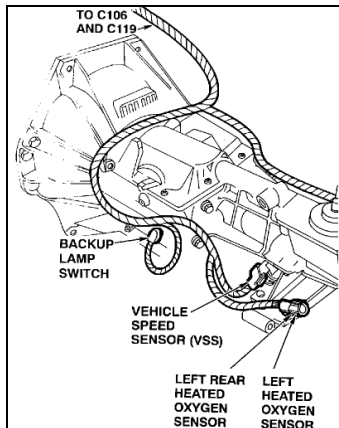

**STEP 3:** Identify the VSS (+) signal output wire. The wire colors are typically GRAY/BLACK on the VSS (+) signal side, and PINK/ORANGE on the VSS (-) return side. Remove the harness wrap to expose approximately 6 inches of the VSS wire leads, and cut the GRAY/BLACK signal wire, insuring that there is enough wire remaining on each side to splice in the wires coming from Speed-Dial.

**DO NOT CUT THE PINK/ORANGE WIRE!!!**

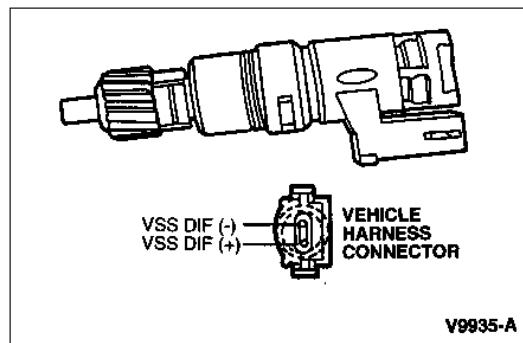

**CONNECTOR FACE**  
(Looking INTO Connector)

**STEP 4:** Once the GRAY/BLACK VSS (+) signal wire has been cut, attach the GREEN wire from Speed-Dial to the cut wire coming FROM the transmission. The GREEN wire on Speed-Dial is the SIGNAL IN.

**Techline 1-800-367-3788**

Factory Ford shop manuals are available from Helm Publications, 1-800-782-4356

IS-1850-0192



# M-4209ADPT-A Speed-Dial (Speedometer Recalibration Tool) INSTRUCTION SHEET

NO PART OF THIS DOCUMENT MAY BE REPRODUCED WITHOUT PRIOR AGREEMENT AND WRITTEN PERMISSION OF FORD RACING PERFORMANCE PARTS

- STEP 5:** Now attach the WHITE wire from Speed-Dial to the remaining GRAY/BLACK cut wire which leads INTO the vehicle harness. The WHITE wire on Speed-Dial is the SIGNAL OUT.
- STEP 6:** Splice the RED wire (using solder and heat shrink) from Speed-Dial to a 12V KEY-ON voltage source. This RED wire should only have voltage when the ignition key is in the 'RUN' position.
- STEP 7:** Finally, attach the BLACK wire from Speed-Dial to a ground source.

**NOTE:** For best results, this ground source should be checked for continuity to the negative side of the battery. An optimum ground path should measure less than 0.5 ohms to the negative battery post. (When measuring resistance, always make sure the key is in the OFF position.)

## SKIP TO PAGE 8 FOR THE SPEED-DIAL SETTING PROCEDURE

## ALTERNATE INSTALLATION FOR UNDERHOOD APPLICATIONS IN 1994-1998 MUSTANG

For under hood installation on a 1994 to 1998 Mustang, the VSS (+) signal wire can also be found at the right rear of the engine compartment in the black 16-Pin connector.

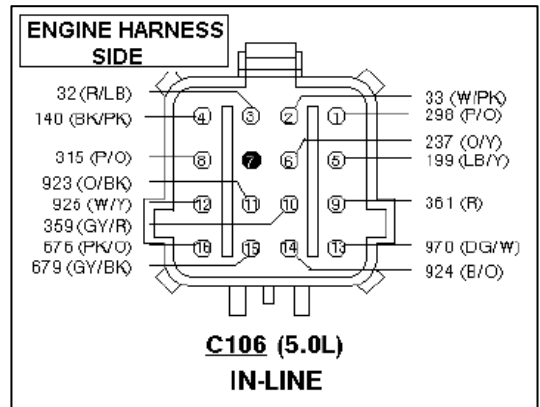
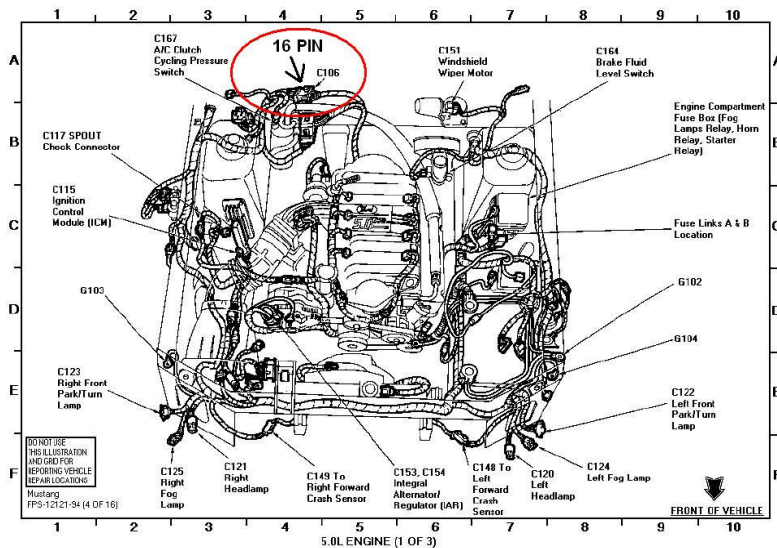

On 4.6L applications, circuit 361 may be located in cavity 5

In the 16 pin connector, identify circuit 679, which should be a GRAY/BLACK wire in cavity 15. This is the VSS (+) signal wire. Use the procedure listed above for installation on this wire. To insure you are working with the correct wire, you should verify continuity to the VSS wire at the transmission BEFORE CUTTING THIS WIRE!

You may also use circuit 361 as the 12V Key-On Source. This should be a RED wire located in cavity 5 or cavity 9. Once again, you should verify that this is the correct wire BEFORE splicing into it!

**Techline 1-800-367-3788**

Factory Ford shop manuals are available from Helm Publications, 1-800-782-4356



# M-4209ADPT-A Speed-Dial (Speedometer Recalibration Tool) INSTRUCTION SHEET

NO PART OF THIS DOCUMENT MAY BE REPRODUCED WITHOUT PRIOR AGREEMENT AND WRITTEN PERMISSION OF FORD RACING PERFORMANCE PARTS

**STEP 8:** 1999 to 2004 Mustang Installation Procedure

**STEP 9:** Identify and disconnect the Output Shaft Speed (OSS) connector from the transmission.

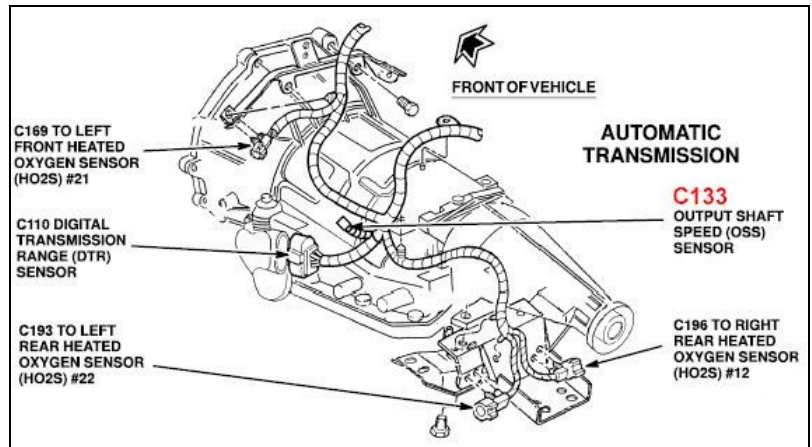
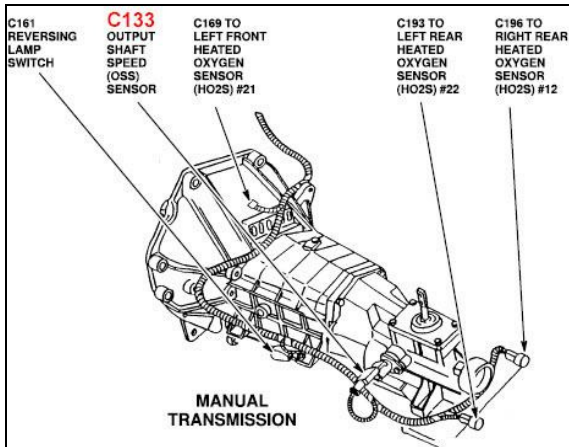

**STEP 10:** Identify the OSS (+) signal output wire. The wire colors are typically GREEN/WHITE on the OSS (+) signal side, and GRAY/RED on the OSS (-) return side. Remove the harness wrap to expose approximately 6 inches of the OSS wire leads, and cut the GREEN/WHITE signal wire, insuring that there is enough wire remaining on each side to splice in the wires coming from Speed-Dial.

**DO NOT CUT THE GRAY/RED WIRE!!!**

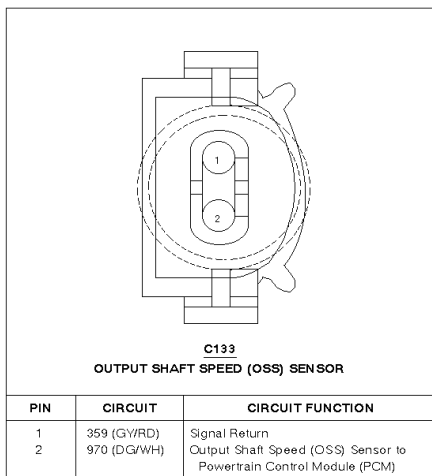

**CONNECTOR FACE**  
(1999-2004 Mustang, Manual Trans)  
(1999-2000 Mustang, Auto Trans)

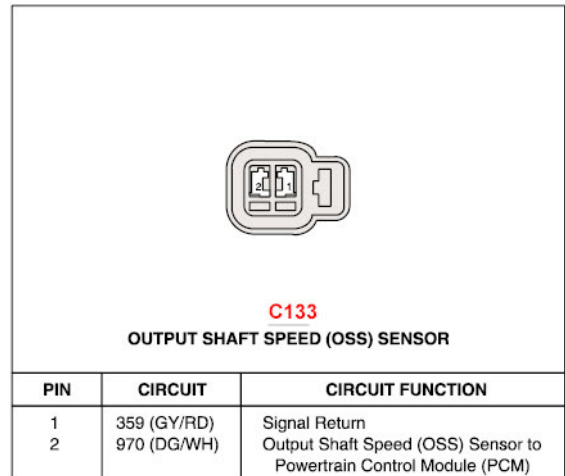

**CONNECTOR FACE**  
(2001-2004 Mustang, Auto Trans)

**Techline 1-800-367-3788**

Factory Ford shop manuals are available from Helm Publications, 1-800-782-4356



# M-4209ADPT-A Speed-Dial (Speedometer Recalibration Tool) INSTRUCTION SHEET

NO PART OF THIS DOCUMENT MAY BE REPRODUCED WITHOUT PRIOR AGREEMENT AND WRITTEN PERMISSION OF FORD RACING PERFORMANCE PARTS

- STEP 11:** Once the GREEN/WHITE OSS (+) signal wire has been cut, attach the GREEN wire from Speed-Dial to the GREEN/WHITE cut wire coming FROM the transmission. The GREEN wire on Speed-Dial is the SIGNAL IN.
- STEP 12:** Now attach the WHITE wire from Speed-Dial to the remaining GREEN/WHITE cut wire which leads INTO the vehicle harness. The WHITE wire on Speed-Dial is the SIGNAL OUT.
- STEP 13:** Splice the RED wire (using solder and heat shrink) from Speed-Dial to a 12V KEY-ON voltage source. This RED wire should have voltage ONLY when the ignition key is in the 'RUN' position.
- STEP 14:** Finally, attach the BLACK wire from Speed-Dial to a ground source.

**NOTE:** For best results, this ground source should be checked for continuity to the negative side of the battery. An optimum ground path should measure less than 0.5 ohms to the negative battery post. (When measuring resistance, always make sure the key is in the OFF position.)

## SKIP TO PAGE 8 FOR THE SPEED-DIAL SETTING PROCEDURE

### ALTERNATE INSTALLATION FOR UNDERHOOD APPLICATIONS IN 1999-04 MUSTANG (except 03/04Cobra)

For under hood installation on a 1999 to 2004 Mustang, the VSS (+) signal wire can also be found at the right rear of the engine compartment in the black 16-Pin connector.

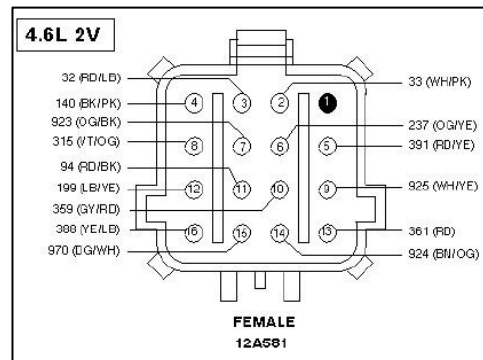
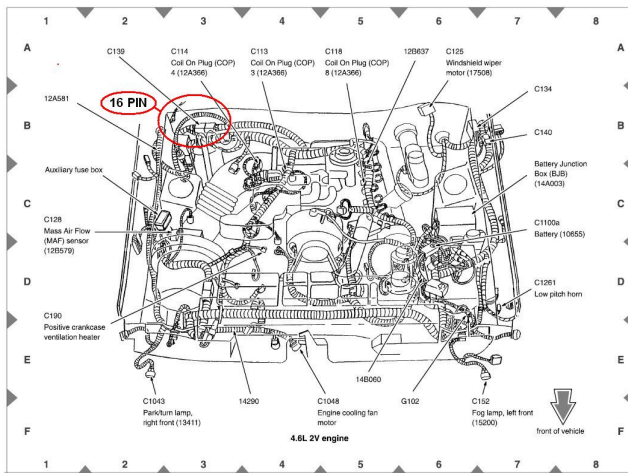

For 99/01 Cobra, circuit 970 is Pin 2

For 03/04 Cobra applications, this under hood option is not available in this connector.

In the 16 pin connector, identify circuit 970, which should be a GREEN/WHITE wire in cavity 15. This is the OSS (+) signal wire. Use the procedure listed above for installation on this wire. To insure you are working with the correct wire, you should verify continuity to the OSS (+) wire at the transmission BEFORE CUTTING THIS WIRE!

You may also use circuit 391 as the 12V Key-On Source. This should be a RED/YELLOW wire located in cavity 5. Once again, you should verify that this is the correct wire BEFORE splicing into it!

**Techline 1-800-367-3788**

Factory Ford shop manuals are available from Helm Publications, 1-800-782-4356



# M-4209ADPT-A Speed-Dial (Speedometer Recalibration Tool) INSTRUCTION SHEET

NO PART OF THIS DOCUMENT MAY BE REPRODUCED WITHOUT PRIOR AGREEMENT AND WRITTEN PERMISSION OF FORD RACING PERFORMANCE PARTS

**STEP 15:** 2005 to 2010 Mustang Installation Procedure

**STEP 16:** Identify and disconnect the Output Shaft Speed (OSS) connector from the transmission.

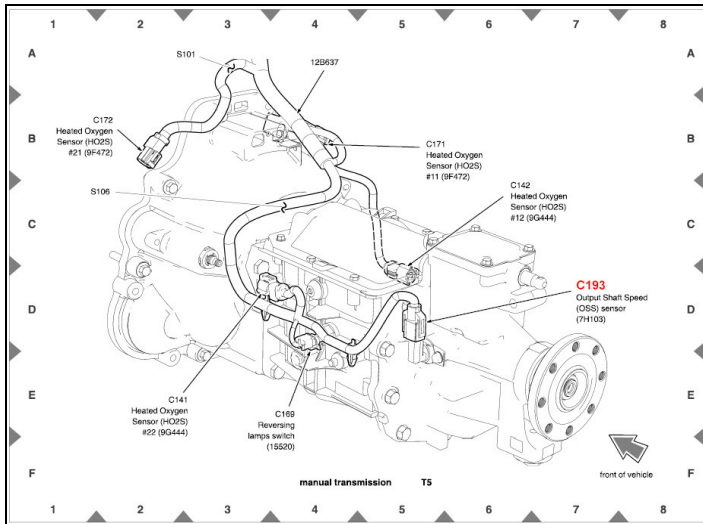

**OSS LOCATION (2005-2010 MUSTANG, MANUAL TRANS)**

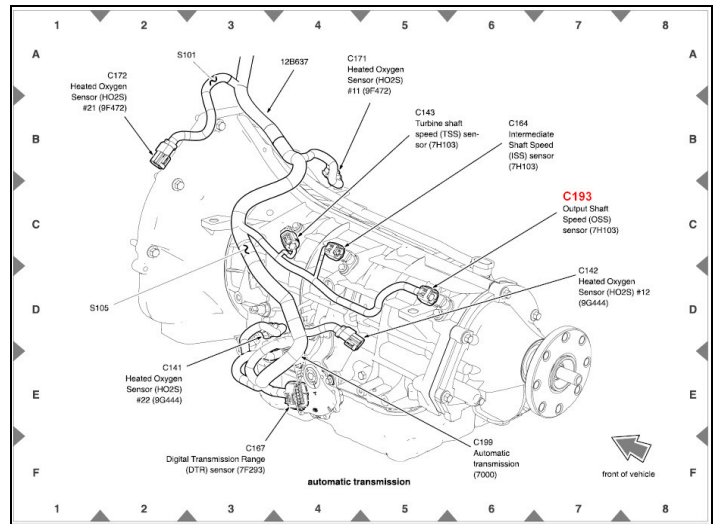

**OSS LOCATION (2005-2010 MUSTANG, AUTOMATIC TRANS)**

**STEP 17:** Identify the signal output wire. The wire colors are typically BLUE/YELLOW on the OSS (+) signal side, and GRAY/RED on the OSS (-) return side. Remove the harness wrap to expose approximately 6 inches of the OSS wire leads, and cut the BLUE/YELLOW signal wire, insuring that there is enough wire remaining on each side to splice in the wires coming from Speed-Dial.

**DO NOT CUT THE GRAY/RED WIRE!!! \*\***

automatic transmission

**FEMALE**

manual transmission

**FEMALE**

Pin	Circuit	Circuit function
1	136 (DB/YE)	Output Shaft Speed (OSS) sensor, signal
2	359 (GY/RD)	signal, return

\*\* For the 2010 Mustang, the OSS (+) signal wire is GRAY/ORANGE, This is the wire that will get cut. The OSS (-) return wire is GREEN/WHITE. **DO NOT CUT THE GREEN/WHITE WIRE!!!**

**Techline 1-800-367-3788**

Factory Ford shop manuals are available from Helm Publications, 1-800-782-4356



## M-4209ADPT-A Speed-Dial (Speedometer Recalibration Tool) INSTRUCTION SHEET

NO PART OF THIS DOCUMENT MAY BE REPRODUCED WITHOUT PRIOR AGREEMENT AND WRITTEN PERMISSION OF  
FORD RACING PERFORMANCE PARTS

**STEP 18:** Once the BLUE/YELLOW OSS (+) signal wire has been cut, attach the GREEN wire from Speed-Dial to the BLUE/YELLOW cut wire coming FROM the transmission. The GREEN wire on Speed-Dial is the SIGNAL IN.

**STEP 19:** Now attach the WHITE wire from Speed-Dial to the remaining BLUE/YELLOW cut wire which leads INTO the vehicle harness. The WHITE wire on Speed-Dial is the SIGNAL OUT.

**STEP 20:** Splice the RED wire (using solder and heat shrink) from Speed-Dial to a 12V KEY-ON voltage source. This RED wire should have voltage ONLY when the ignition key is in the 'RUN' position.

**STEP 21:** Finally, attach the BLACK wire from Speed-Dial to a ground source.

**NOTE:** For best results, this ground source should be checked for continuity to the negative side of the battery. An optimum ground path should measure less than 0.5 ohms to the negative battery post. (When measuring resistance, always make sure the key is in the OFF position.)

**Techline 1-800-367-3788**

Factory Ford shop manuals are available from Helm Publications, 1-800-782-4356



# M-4209ADPT-A Speed-Dial (Speedometer Recalibration Tool) INSTRUCTION SHEET

NO PART OF THIS DOCUMENT MAY BE REPRODUCED WITHOUT PRIOR AGREEMENT AND WRITTEN PERMISSION OF FORD RACING PERFORMANCE PARTS

## SPEED-DIAL SETTING PROCEDURE:

There are 3 separate methods to determine the proper ratio to dial into Speed-Dial

### **FIRST METHOD:**

If an axle ratio change has been made, and the speedometer read properly before making this change, this can be figured by dividing the OLD numerical gear by the NEW numerical gear ratio. For example, if the vehicle was originally equipped with 3.27 gears, and is replaced with 3.73 gears, use the following math equation:

$$\frac{\text{OLD GEAR}}{3.27} \quad / \quad \frac{\text{NEW GEAR}}{3.73} \quad = \quad \frac{\text{RATIO CHANGE}}{0.88 \text{ (rounded off to nearest 100th)}}$$

**Set Speed-Dial to "0-8-8"**

If the vehicle originally had 4.56 gears, and is replaced with 3.55 gears, use the same equation:

$$\frac{\text{OLD GEAR}}{4.56} \quad / \quad \frac{\text{NEW GEAR}}{3.55} \quad = \quad \frac{\text{RATIO CHANGE}}{1.28 \text{ (rounded off to nearest 100th)}}$$

**Set Speed-Dial to "1-2-8"**

### **SECOND METHOD:**

If a tire change has been made, and the speedometer read properly before making this change, this can be figured by dividing the NEW tire diameter by the OLD tire diameter. For example, if a truck originally had a 29" tall tire, and is replaced with a 35" tire, use the following math equation:

$$\frac{\text{NEW TIRE}}{34.5" \text{ (actual)}} \quad / \quad \frac{\text{OLD TIRE}}{28.8" \text{ (actual)}} \quad = \quad \frac{\text{RATIO CHANGE}}{1.20 \text{ (rounded off to nearest 100th)}}$$

**Set Speed-Dial to "1-2-0"**

### **THIRD METHOD:**

If a starting point is uncertain, it is still possible to determine the proper ratio using the vehicle's trip odometer. Run the vehicle on a highway paying special attention to the mile markers on the side of the road. While driving past a mile marker, identify the mile marker number as you press the reset button on the trip odometer. After traveling 10 miles (as measured against the mile markers), make note of the trip odometer reading. If the trip odometer reads 12.2 miles, use the following equation to determine the proper ratio:

$$\frac{\text{ACTUAL DISTANCE}}{10 \text{ (miles)}} \quad / \quad \frac{\text{MEASURED DISTANCE}}{12.2 \text{ (miles)}} \quad = \quad \frac{\text{RATIO CHANGE}}{0.82 \text{ (rounded off)}}$$

**Set Speed-Dial to "0-8-2"**

## TROUBLESHOOTING:

To determine if Speed-Dial is wired correctly, set the dials to 0-0-0 and it will generate an 11.74mph plus or minus 1 signal when the key is on.

**Techline 1-800-367-3788**

Factory Ford shop manuals are available from Helm Publications, 1-800-782-4356