



Part Number: M-20201-M
Part Description: Mustang Strut Tower Brace Kit
INSTALLATION INSTRUCTIONS

NO PART OF THIS DOCUMENT MAY BE REPRODUCED WITHOUT PRIOR AGREEMENT AND WRITTEN PERMISSION OF FORD RACING PERFORMANCE PARTS.

Please visit www.fordracingparts.com for the most current instruction information

!!! PLEASE READ ALL OF THE FOLLOWING INSTRUCTIONS CAREFULLY PRIOR TO INSTALLATION.

AT ANY TIME YOU DO NOT UNDERSTAND THE INSTRUCTIONS, PLEASE CALL THE FORD RACING TECHLINE AT 1-800-367-3788 !!!

OVERVIEW:

Strut Tower Brace



Strut Tower Brace Kit Contains the Following

- 1** **Strut Tower Brace**
- 1** **Cowl Extension**
- 4** **Nuts**

Factory Ford shop manuals are available from Helm Publications, 1-800-782-4356



Part Number: M-20201-M
Part Description: Mustang Strut Tower Brace Kit
INSTALLATION INSTRUCTIONS

NO PART OF THIS DOCUMENT MAY BE REPRODUCED WITHOUT PRIOR AGREEMENT AND WRITTEN PERMISSION OF FORD RACING PERFORMANCE PARTS.

Windshield Wiper Pivot Arm

Special Tool(s) / General Equipment

Two Leg Puller

Removal

NOTE: *Removal steps in this procedure may contain installation details.*

1. Remove the windshield wiper pivot arm nut covers.

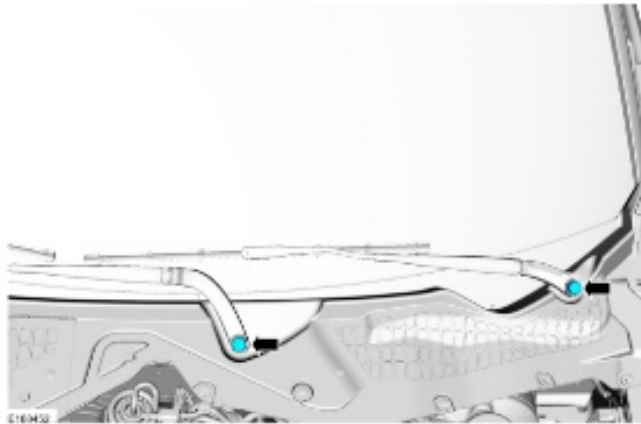

2. Remove the windshield wiper pivot arm nuts.
Torque: 26 lb.ft (35 Nm)

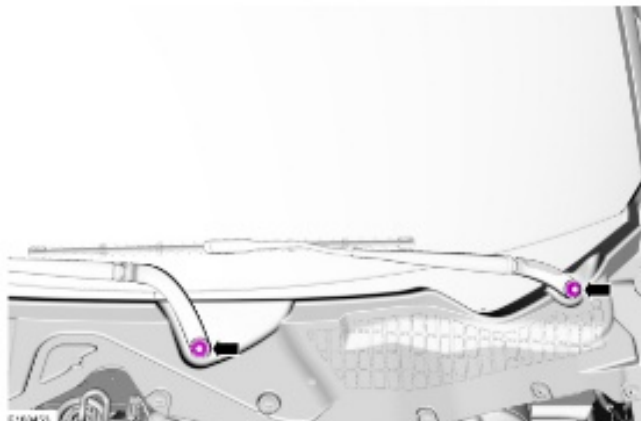

Factory Ford shop manuals are available from Helm Publications, 1-800-782-4356

NO PART OF THIS DOCUMENT MAY BE REPRODUCED WITHOUT PRIOR AGREEMENT AND WRITTEN PERMISSION OF FORD RACING PERFORMANCE PARTS.

3. Remove the windshield wiper pivot arms.
Use the General Equipment: Two Leg Puller

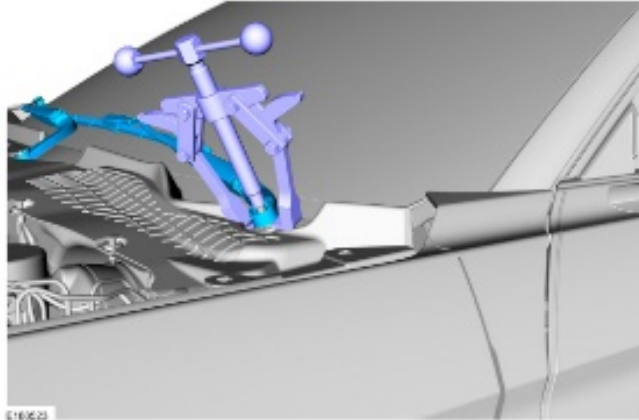

Battery Disconnect and Connect

Disconnect

NOTE: When the battery is disconnected and connected, some abnormal drive symptoms may occur while the vehicle relearns its adaptive strategy. The vehicle may need to be driven to allow the PCM to relearn the adaptive strategy values.

1. Remove the retainers and the battery cover.

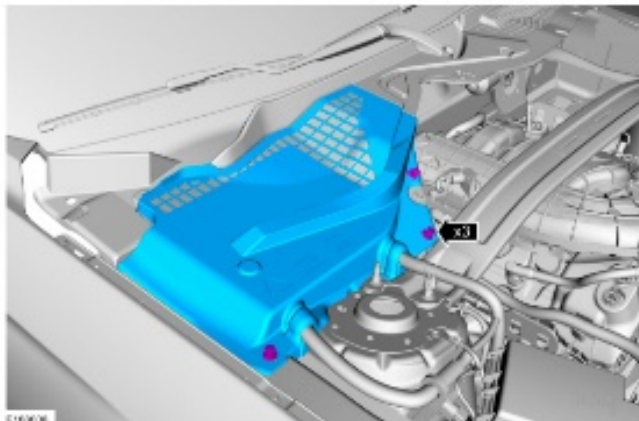

NO PART OF THIS DOCUMENT MAY BE REPRODUCED WITHOUT PRIOR AGREEMENT AND WRITTEN PERMISSION OF FORD RACING PERFORMANCE PARTS.

2. Loosen the nut and position the negative battery cable.
Torque: 44 lb.in (5 Nm)

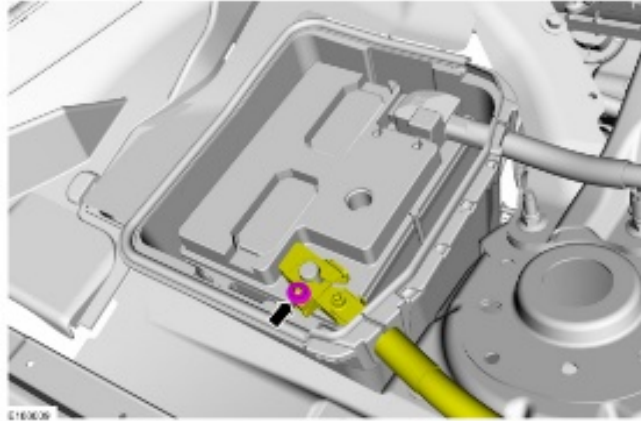

3. Position the positive battery cable cover, loosen the nut and position the positive battery cable.
Torque: 44 lb.in (5 Nm)

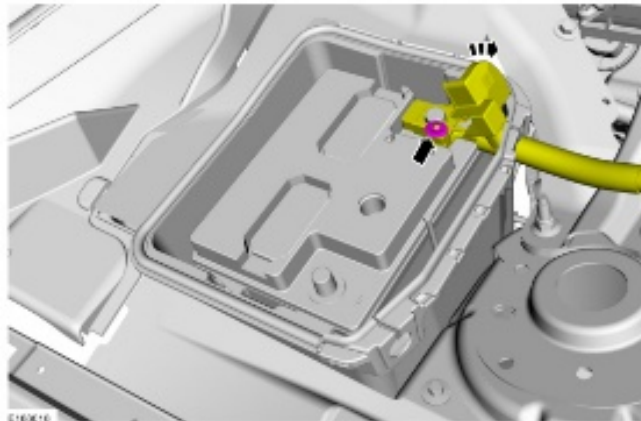

Connect

1. To connect, reverse the disconnect procedure.

NO PART OF THIS DOCUMENT MAY BE REPRODUCED WITHOUT PRIOR AGREEMENT AND WRITTEN PERMISSION OF FORD RACING PERFORMANCE PARTS.

Cowl Panel Grille

Removal

Remove the retainers and the clips.

1. Remove the 7 reusable retainers.
2. Depress and remove the clips.

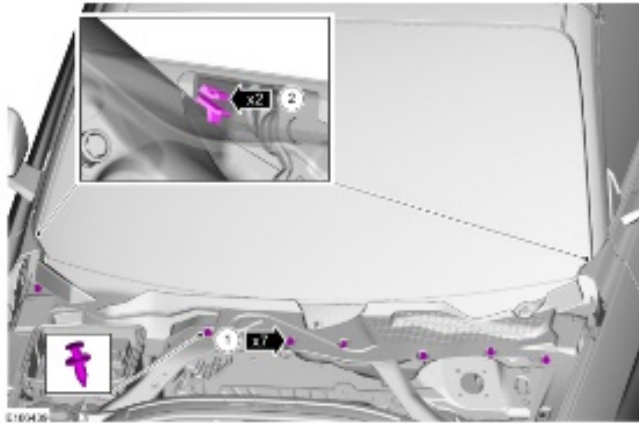

3. Lift the cowl panel grille up.
4. Pull the cowl panel grille out and remove.

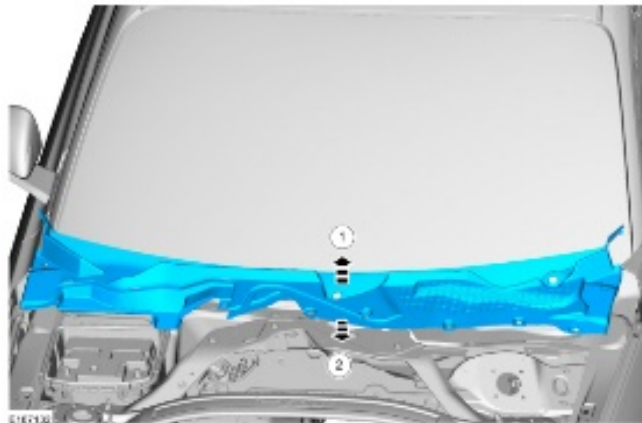

NO PART OF THIS DOCUMENT MAY BE REPRODUCED WITHOUT PRIOR AGREEMENT AND WRITTEN PERMISSION OF FORD RACING PERFORMANCE PARTS.

Strut Tower Cross Brace Removal – If Equipped

1. Detach the wiring harness retainer.
2. Remove the nuts and the strut tower cross brace.

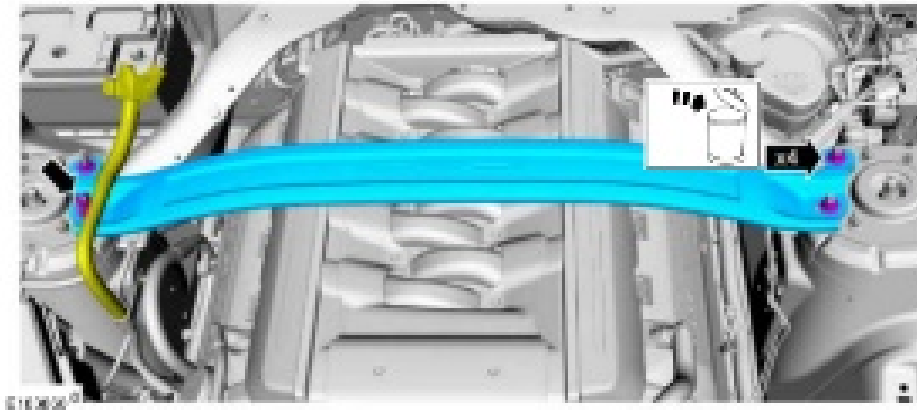

3. Remove the fasteners and the cowl extension.

Note: Ford Racing cowl extension is the same as Original Equipment.

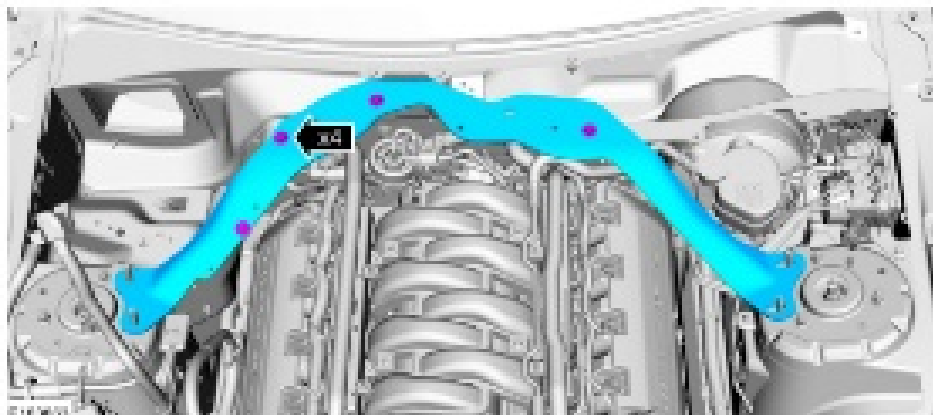

NO PART OF THIS DOCUMENT MAY BE REPRODUCED WITHOUT PRIOR AGREEMENT AND WRITTEN PERMISSION OF FORD RACING PERFORMANCE PARTS.

Installing Your New Strut Tower Cross Brace

1. Install your new cowl extension with the original fasteners.
Torque: 26 lb.ft (35 Nm)

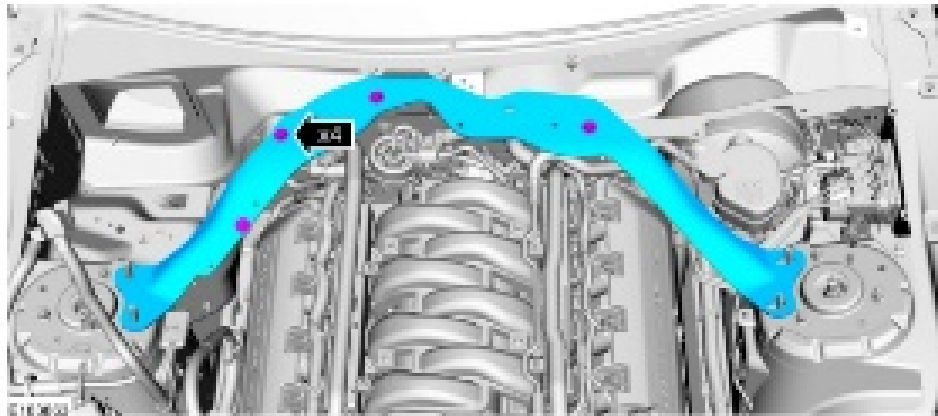

2. Install the new strut tower cross brace with new nuts.
Torque: 41 lb.ft (55 Nm)

3. Attach the wiring harness retainer.

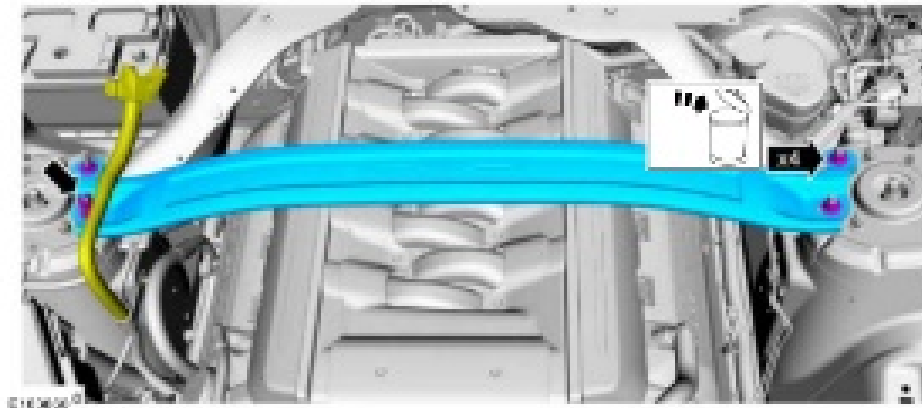

Installation of Cowl Panel

1. To install, reverse the removal procedure from earlier in the instructions.



Part Number: M-20201-M
Part Description: Mustang Strut Tower Brace Kit
INSTALLATION INSTRUCTIONS

NO PART OF THIS DOCUMENT MAY BE REPRODUCED WITHOUT PRIOR AGREEMENT AND WRITTEN PERMISSION OF FORD RACING PERFORMANCE PARTS.

Battery Connect

Connect

1. To connect, reverse the disconnect procedure from earlier in the instructions.

Windshield Wiper Pivot Arm

Installation

1. Verify the windshield wiper motor is in the PARK position.
 1. Set the ignition switch to the ON position.
 2. Set the windshield wiper switch to run the wipers one complete cycle.

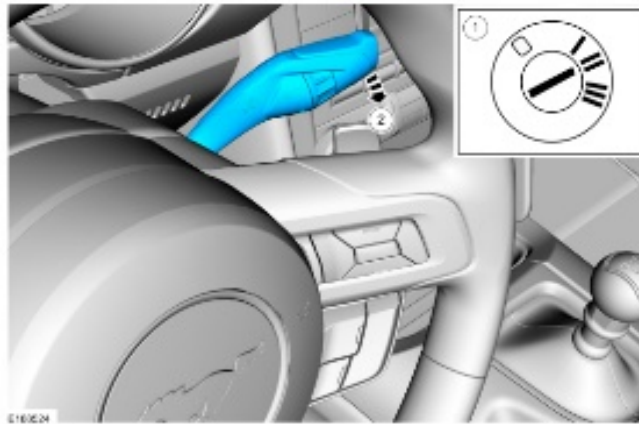

2. Install the windshield wiper pivot arms.
 1. Align the windshield wiper blades inside the marks on the windshield.
 2. Install the windshield wiper pivot arm nuts.
Torque: 26 lb.ft (35 Nm)
 3. Turn the ignition switch off.

Factory Ford shop manuals are available from Helm Publications, 1-800-782-4356



Part Number: M-20201-M
Part Description: Mustang Strut Tower Brace Kit
INSTALLATION INSTRUCTIONS

NO PART OF THIS DOCUMENT MAY BE REPRODUCED WITHOUT PRIOR AGREEMENT AND WRITTEN PERMISSION OF FORD RACING PERFORMANCE PARTS.

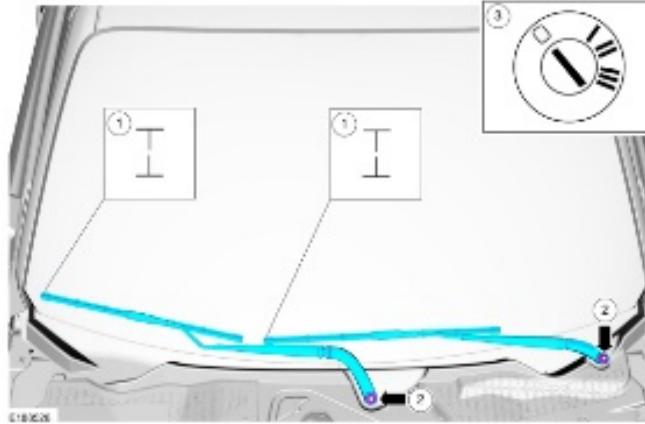

3. Install the windshield wiper pivot arm nut covers.

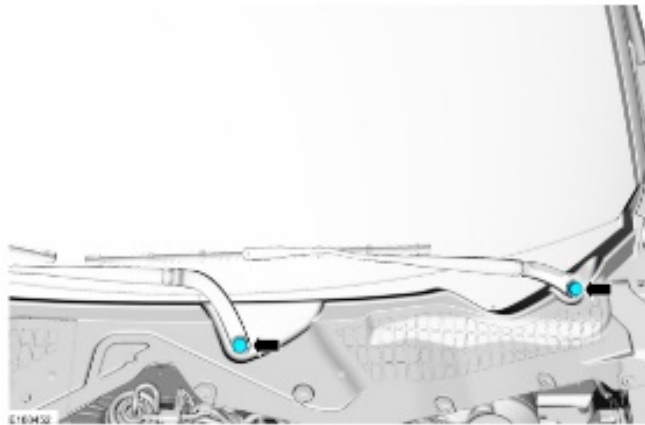

4. Start vehicle and verify wiper operation.

NOTE: When the battery is disconnected and connected, some abnormal drive symptoms may occur while the vehicle relearns its adaptive strategy. The vehicle may need to be driven to allow the PCM to relearn the adaptive strategy values.

Factory Ford shop manuals are available from Helm Publications, 1-800-782-4356