

NO PART OF THIS DOCUMENT MAY BE REPRODUCED WITHOUT PRIOR AGREEMENT AND WRITTEN PERMISSION OF FORD RACING PERFORMANCE PARTS.

Please visit www.fordracingparts.com for the most current instruction and warranty information.

**!!! PLEASE READ ALL OF THE FOLLOWING INSTRUCTIONS CAREFULLY PRIOR TO INSTALLATION.
AT ANY TIME YOU DO NOT UNDERSTAND THE INSTRUCTIONS, PLEASE CALL THE FORD RACING
TECHLINE AT 1-800-367-3788 !!!**

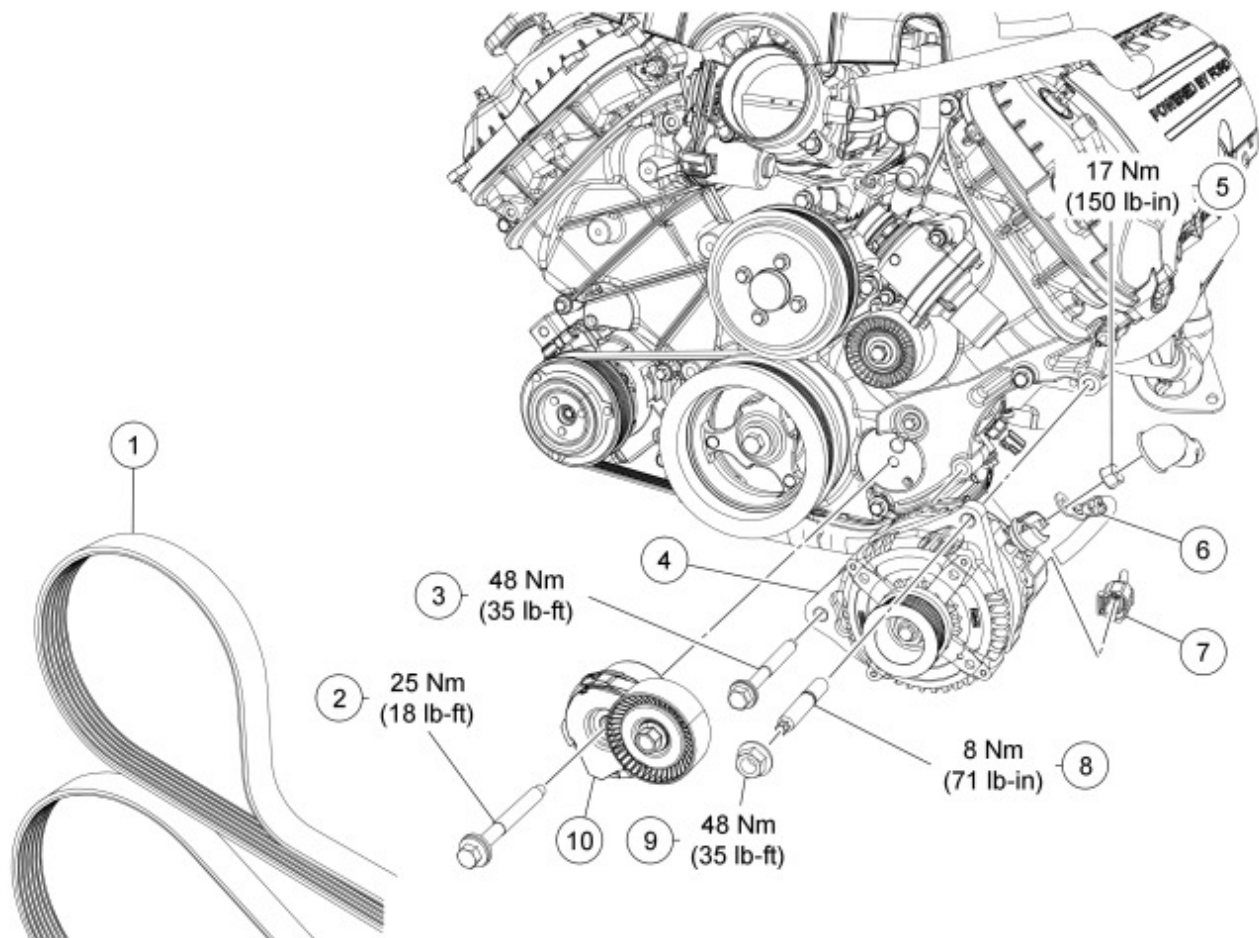

NO PART OF THIS DOCUMENT MAY BE REPRODUCED WITHOUT PRIOR AGREEMENT AND WRITTEN PERMISSION OF FORD RACING PERFORMANCE PARTS.

Item	Description
1	Front End Accessory Drive (FEAD) belt (in kit)
2	FEAD belt tensioner bolt (in kit)
3	Alternator bolt (in kit)
4	Alternator (in kit)
5	Alternator B+ terminal nut (reference only)
6	Alternator B+ terminal (reference only)
7	Alternator electrical connector (reference only)
8	Alternator stud (in kit)
9	Alternator stud nut (in kit)
10	FEAD belt tensioner (in kit)

5.0L (4V) Front End Accessory Drive (FEAD)

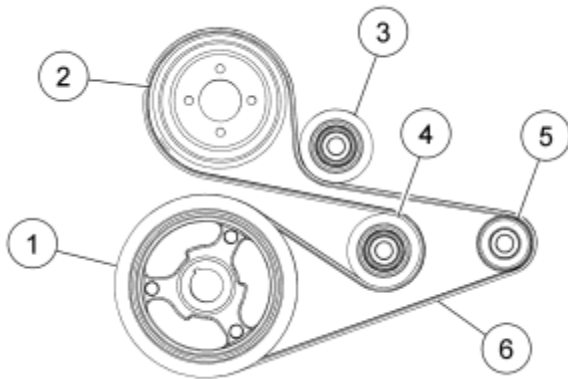

Item	Description
1	Crankshaft pulley (on engine)
2	Coolant pump pulley (on engine)
3	Accessory drive belt idler pulley (on engine)
4	Accessory drive belt tensioner pulley
5	Alternator and pulley
6	Accessory drive belt

NO PART OF THIS DOCUMENT MAY BE REPRODUCED WITHOUT PRIOR AGREEMENT AND WRITTEN PERMISSION OF FORD RACING PERFORMANCE PARTS.

Belt Tensioner With Belt Length Indicator — 5.0L

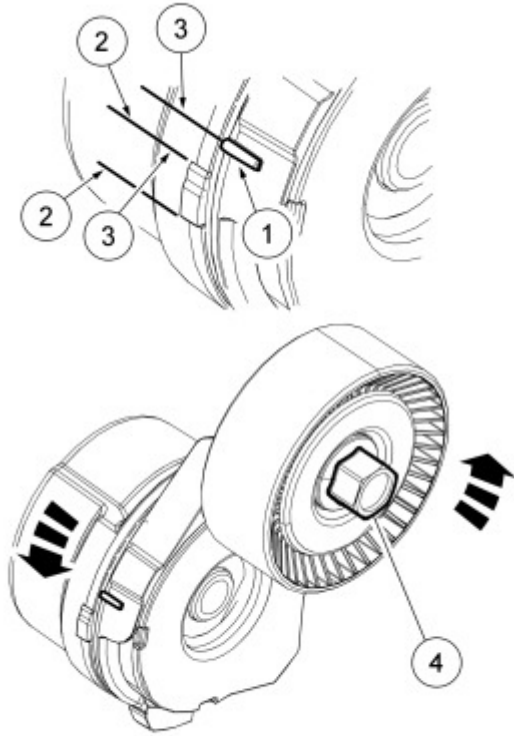

Item	Description
1	Belt length indicator
2	Acceptable belt installation and wear range
3	Belt replacement range
4	Belt tension relief point

NO PART OF THIS DOCUMENT MAY BE REPRODUCED WITHOUT PRIOR AGREEMENT AND WRITTEN PERMISSION OF FORD RACING PERFORMANCE PARTS.

Incorrect Installation



Correct Installation

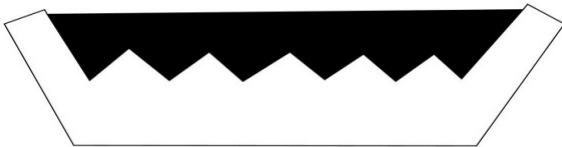

With the engine running, check accessory drive belt tracking on all pulleys. If the edge of the accessory drive belt rides beyond the edge of the pulleys, noise and premature wear will occur. Make sure the accessory drive belt rides correctly on the pulley. If an accessory drive belt tracking condition exists, proceed with the following:

- Visually check the accessory drive belt tensioner for damage and wear, especially the mounting pad surface and arm alignment. If the accessory drive belt tensioner is not installed correctly, the mounting surface pad will be out of position. If the tensioner arm is worn, the arm will be out of alignment. Either of these conditions will result in chirp and squeal noises.
- With the engine running, visually observe the grooves in the pulleys (not the pulley flanges or the pulley forward faces) for excessive wobble. Install new components as necessary.
- Check all accessories, mounting brackets and the accessory drive belt tensioner for any interference that would prevent the component from mounting correctly. Correct any interference condition and recheck the accessory drive belt tracking.
- Tighten all accessories, mounting brackets and accessory drive belt tensioner retaining hardware to specification. Recheck the accessory drive belt tracking.