

## WE THOUGHT YOU OUGHT TO KNOW

This is not a how-to book. It's basically a listing of currently available Ford Racing Performance Parts. The pieces can be bought by professionals, professional amateurs, weekend hobbyists or rank beginners. A certain amount of automotive skill is assumed in presenting the parts. Modifying an engine, be it a complete assembly or a bare block, requires experience and know-how. If you don't know, ask someone who does. Read up and find out all you can **before** putting down your bucks for those long dreamed of pieces. And if at all possible, consult an experienced engine builder. You may find it to your advantage to have him do a portion or all of the heavy machining and wrenching.

What we have here are just a few of the key bits of info and specs. The idea is to help keep midnight thrashing to a minimum, because parts don't go together right, or there's more to a job than you imagined.

## COMPRESSION RATIO

Increasing the compression ratio (CR) is often one of the first engine performance modifications. Squeezing the air-fuel mixture into a smaller space increases its temperature and ease of ignition; thus the rate at which heat is extracted from the fuel. Engineers call it "thermal efficiency." Simply put, it means that increasing the compression ratio increases horsepower.

Henry Ford's Model "T" has a CR of 3.6:1. High performance engines operate in the area of 12.5:1. Most of today's stock production engines are about 8.5:1.

**NOTE:** Turbocharged engines typically have a **lower** CR than normally aspirated engines. Thus, if you add a turbo, you may want to **lower** the CR, depending on performance level.

## DETONATION

Increasing the CR changes the rate at which fuel burns. Spark knock (detonation) will occur if certain modifications are not performed.

Here are two of the most important:

**Ignition Spark Timing** — Increasing the CR requires installation of new distributor springs to change advance curve.

**Fuel Octane Rating** — Increasing the CR requires gasoline with a high octane rating (with anti-knock components to control detonation). This is not a problem with engines that burn alcohol, because it has a naturally high octane number. Engines that run on alcohol require a high CR to compensate for the fact that it generates less heat.

## MODIFICATION TECHNIQUES

Common techniques to increase CR include:

- (1) Installation of a thinner head gasket.
- (2) Installation of "domed" or "pop-up" pistons. Check for adequate "piston-to-valve" clearance at TDC. Camshafts with more overlap require more clearance. A good rule of thumb is 0.080" for intakes and 0.100" for exhausts.
- (3) Removal of metal from deck face of block or cylinder head. You can safely mill off 0.010" to 0.040" (0.050" max.) from most engines.

## COMPRESSION RATIO CALCULATION

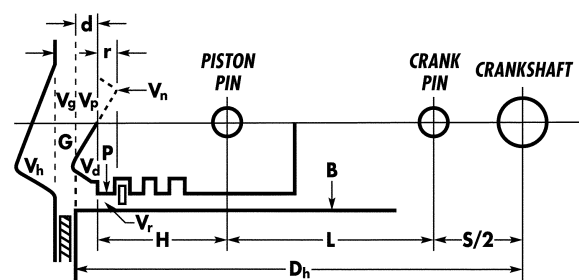

SYMBOL	DIMENSION	VALUE	REMARKS
B	Bore	4.000 in	$B^2 = 4.000 \times 4.000 = 16.000$
G	Gasket Bore	4.100 in	$G^2 = 4.100 \times 4.100 = 16.810$
P	Piston Top Land Diameter	3.965 in	$P^2 = 3.965 \times 3.965 = 15.721$
S	Stroke	3.500 in	
S/2	Crank Throw	1.750 in	
L	Con Rod Length	6.000 in	
H	Compression Height	1.440 in	
Dh	Deck Height	9.200 in	
r	Ring-to-Top Piston	0.250 in	
d	Piston to Deck	0.010 in	$D_h - H - L - S/2$
t	Gasket Thickness	0.040 in	
V	Cylinder Volume	720.7cc	$\pi/4 \times B^2 \times S \times 16.387$
Vt	Volume Above Top Ring	.9cc	$\pi/4 \times (B^2 - P^2) \times r \times 16.387$
Vn	Valve Notches Volume	4.0cc	
Vd	Dome Volume	10.4cc	
Vp	Piston-to-Deck Volume	2.1cc	$\pi/4 \times B^2 \times d \times 16.387$
Vg	Gasket Volume	8.7cc	$\pi/4 \times G^2 \times t \times 16.387$
Vh	Volume Head	60.2cc	
Vc	Volume Clearance	65.5cc	$V_t + V_n + V_p + V_g + V_h - V_d$
CR	Compression Ratio	12.0	$\frac{V + V_c}{V_d}$

**NOTE:** 1) Math reduction;  $\pi/4 \times 16.387 = 12.87$

The precise amount is limited by block deck height, casting thickness, valve-to-piston clearance, etc.

**NOTE:** Also modify the intake manifold to maintain port alignment.

## COMPUTING COMPRESSION RATIO

Compression ratio is defined as the ratio between the Total Volume (Cylinder Volume plus Clearance Volume) above the piston at BDC and the Clearance Volume above it at TDC.

Calculations for a 351 CID engine are illustrated. The formula is:  $CR = \frac{V + V_c}{V_d}$

Pay particular attention to the following points:

**Clearance Volume (V<sub>c</sub>)** — This is the volume above the piston (actually above top piston ring) at TDC. It consists of several small volumes.

**Cylinder (Swept) Volume (V)** — Determined by cylinder bore and stroke (indicated by movement of piston from TDC to BDC).

## Cylinder Head (Combustion Chamber) Volume (V<sub>h</sub>)

Volume (V<sub>h</sub>) — The irregular shape of the combustion chamber requires measurement (popularly called "cc'ing" with a glass burette and colored liquid, such as A.T. fluid. This catalog lists "nominal" values for Ford Racing heads.

**Valve Notches Volume (V<sub>n</sub>)** — Fill notches with soft clay and make level with top of piston. Remove clay with small knife and drop into graduated cylinder (filled with liquid to convenient point). Note change in level of liquid (indicating volume of notches made by clay).

**Domed Piston Volume (V<sub>d</sub>)** — Dome values are combination "net" values of V<sub>d</sub> and V<sub>n</sub>. For compression ratio calculations, they should be used as follows:

- **Pop-Up** pistons have a "positive" dome value, which reduces the volume above the piston and thus must be subtracted (see example above).
- **Dished pistons** have a "negative" dome value. It must be added to compute clearance volume.

**MAKE ALL CALCULATIONS WITH ACCURATE MEASUREMENTS OF ACTUAL PARTS. CATALOG VALUES ARE "NOMINAL" SPECIFICATIONS AND MAY VARY FROM ACTUAL SIZE.**

## VALVE TRAIN

When modifying production engines for performance, here are a few things to keep in mind.

### CAMSHAFTS

- When replacing a cam, it's a good practice to install new related components such as distributor gear, tappets, springs, retainers, etc. It's especially important that new tappets be installed.
- Never use hydraulic lifters with a mechanical cam or solid tappets with a hydraulic cam. The ramps are not compatible.
- Be sure your valve train can handle the timing events and lobe lift of your performance cam. Check for adequate piston-to-valve clearance, spring bind and retainer-to-valve clearance, spring bind and retainer-to-valve seal clearance.
- Be sure to use camshaft and lifter prelude when installing the cam, to prevent scoring the lobes during break-in. Engine oil by itself (regardless of quality or viscosity) is not enough! See page 79 for description of Ford Racing prelude M-19579-A991.
- Mechanical cams require lash adjustment. If production head is designed for hydraulic cam, modification is usually required.
- Many design changes have occurred over the years, which affect the front of the block — especially the small V-8's. Be sure you check items such as the cam thrust plate, cam spacers, cam gear, fuel pump eccentric, timing chain, cam gear alignment and front cover clearance.
- Refer to the Ford Racing "Camshaft Usage" chart for performance characteristics of cams based on their duration.
- Refer to the "Camshaft Specifications" chart (page 80) for detailed data on Ford Racing camshafts.

## FORD RACING CAMSHAFT USAGE

The durations shown in this chart are S.A.E. durations. The descriptions within each group of cams show performance characteristics and basic modification recommendations required to achieve desired performance.

DURATION (SAE)	PERFORMANCE CHARACTERISTICS	ENGINE/VEHICLE USAGE AND MODIFICATIONS
270-290	Good idle quality and low RPM torque.	Use with stock or slightly modified engine, stock axle gears and with A.T. or M.T.
290-300	Fair idle quality. Good low-to-mid-range torque and horsepower.	Will work with stock or modified engine. Can use stock axle gears and with A.T. or M.T.
300-320	Rough idle quality. Good mid-to-high RPM torque and horsepower.	Use with M.T. or high stall A.T. Requires improved carburetion, ignition and exhaust systems. Engine will have lower vacuum than stock.
320-340	Rough idle quality. Good mid-to-high RPM torque and horsepower. For all-out competition only.	Use with M.T. or very high stall A.T. Requires improved carburetion, ignition and exhaust systems. Engine will not provide enough vacuum for accessories. Axle gear ratios must be properly selected.

### ROLLER TAPPET CAMSHAFT

Most engines are designed with hydraulic or mechanical flat tappet camshafts, which meet the needs of regular production engines that seldom see 6000 RPM. Flat tappet cams are more than adequate for many competition engines. For ultra-high performance applications where durability and high RPM capability are paramount, however, roller tappet camshafts are very popular. As the name implies, a cylindrical roller "rolls" over the cam lobe, instead of "sliding" as does a conventional flat tappet. This not only allows a roller tappet to follow a more radical cam lobe profile, but it reduces friction and lessens tappet scuffing of the cam lobes.

Ford introduced hydraulic roller tappet camshafts on 1985 Mustang (and Mark VII LSC) with 302 (5.0L) High Output engine. Here is a brief description of components.

**Roller Tappet** — Longer than flat tappet, because of roller. Hydraulic portion functions like a standard flat tappet.

**Roller Tappet Camshaft** — Machined from steel, instead of typical iron used for flat tappet cam. Cam lobes specially ground and hardened to withstand loads of roller tappets. Do not attempt to use with flat tappets!

**Roller Tappet Block** — Longer, production 5.0L hydraulic roller tappet requires higher tappet boss than block for flat tappet cam. Thus, 5.0L hydraulic roller tappet cam cannot be used in block designed for flat tappet cam. However, flat tappet camshafts can be used in roller tappet blocks.

**Roller Tappet Distributor Gear** — Machined from steel and specially hardened to be compatible with billet-steel roller camshaft. Do not attempt to use cast iron gears designed for flat tappet cams.

**Roller Tappet Push Rod** — Push rods are shorter than those designed for flat tappet cam engine, because of longer roller tappet. Rocker arm end has hardened ball that is copper plated to resist wear by rocker arms rubbing on push rod (which don't rotate). A small bracket encircles one end of push rod as reminder to install that end upward (on 1985-86 models only).

**Roller Tappet Guide Plate** — Holds roller tappets in alignment with camshaft lobes (flat tappets rotate). Must be installed with "UP" marking upward.

**Roller Tappet Guide Plate Retainer** — Made of spring steel. Fits in valley cover area to hold guide plates in position.

### ROLLER ROCKER ARMS

Most production engines use stamped steel or cast iron rocker arms, as described on page 158. As the push rod moves one end upward — the rocker arm pivots on a ball or sled-type fulcrum — and the other end pushes the valve downward. Although "sliding" friction exists at each point, this design is okay for street engines and even many performance applications.

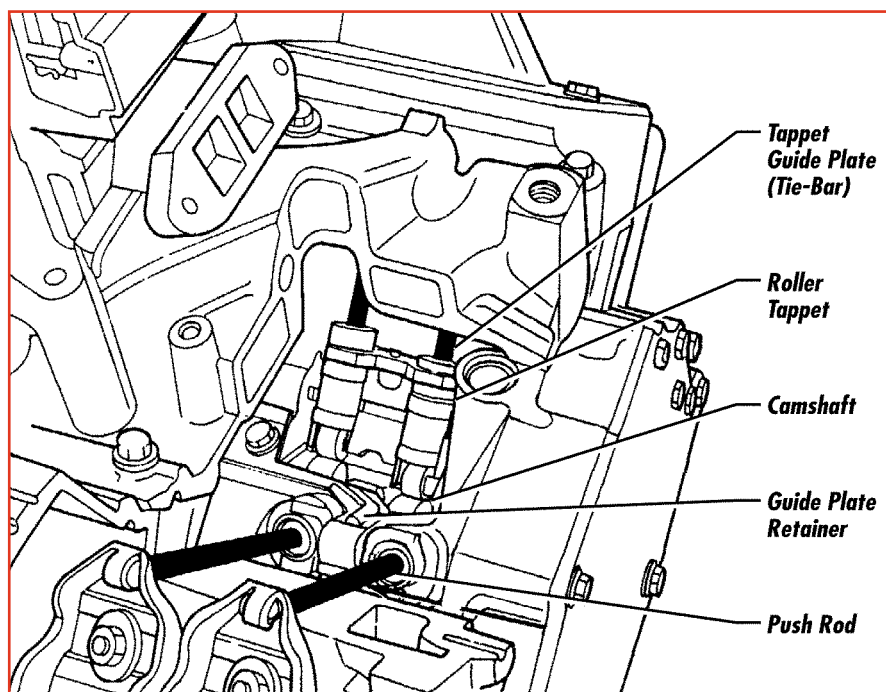

## ROLLER ROCKER ARMS

(Continued from page 157)

Lightweight aluminum roller rocker arms, however, provide many advantages for continuous high RPM operation. They're mounted on needle bearings and feature a cylindrical roller that "rolls" over the valve tip to move it downward. This reduces friction, heat and wear, and only requires about half the horsepower to operate the valve train. And valve train stability is greatly increased. Roller rockers reduce valve stem wear and valve guide wear to an absolute minimum, because the roller doesn't push the valve from side-to-side as it is opened, as occurs with standard rocker arms, as they "slide" over the valve tip.

Ford Racing offers roller rocker arms in several ratios for the Ford Racing V-6, small block V-8's and big block 429/460 V-8's.

## FORD RACING ROLLER TAPPET CAMSHAFTS

Ford Racing offers roller tappet camshafts for the following engines:

### 5.0L (302) HO

- M-6250-B303\*** Roller Camshaft only
- M-6250-E303\*** Roller Camshaft only
- M-6250-F303\*** Roller Camshaft only
- M-6250-X303\*** Roller Camshaft only
- M-6250-Z303\*** Roller Camshaft only

## VALVE SPRING RETAINERS & KEEPERS

Currently Ford Racing only offers retainers and single-lock groove keepers in a 7-degree design. They are compatible with all Ford Racing valve springs for the Ford Racing V-6, small block V-8's and big block 429/460 V-8's. 10-degree retainers/keepers are available from aftermarket suppliers. Do not attempt to interchange 7-degree retainers with 10-degree keepers and vice versa.

Single-lock groove keepers are recommended for high performance engines. Production 351C (except BOSS and HO) 351M and 400 engines use multi-groove keepers (to promote valve rotation). If you modify for any extended high revving performance, replace the valves, retainers and keepers with a single-lock groove design.

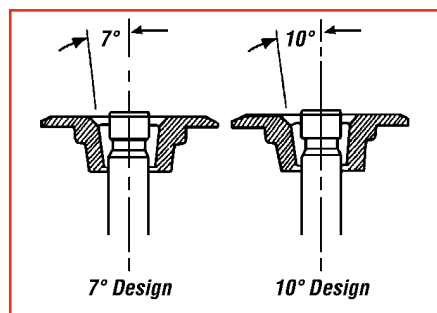

## POSITIVE-TYPE OIL SEALS

Positive-type oil seals are recommended on OHV performance engines to prevent oil from running down the valve past the valve guide and into the combustion chamber and contaminating the air-fuel mixture. The cylinder head must be machined as illustrated to accept the oil seal.

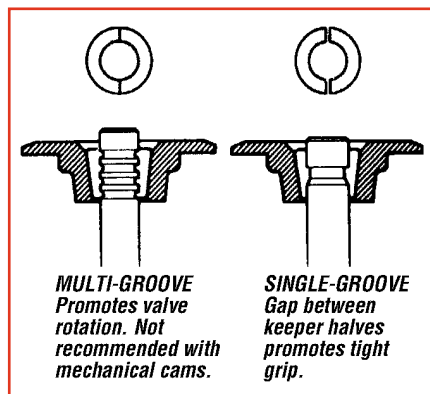

## VALVE PUSH RODS

Hardened push rods are required on valve trains that use a guide plate (because they rub against the plate). Do not use non-hardened push rods.

Push rod length is important to maintain correct valve train geometry. The process of drilling an oil hole down the center removes some material from the spherical ball at each end. Push rods are described by "Gage length" (the distance between the ends before drilling the oil hole). The actual "Measured" length is usually about 0.025" shorter than the gage length.

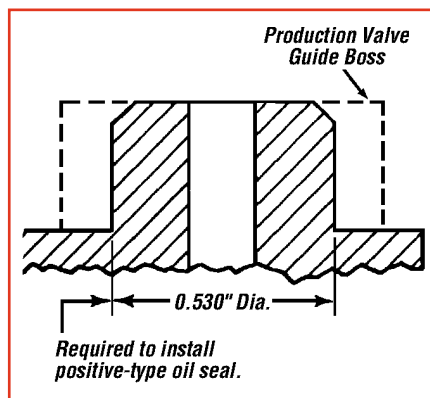

## CAMSHAFT TIMING DEGREE WHEEL

No camshaft installation is complete without checking camshaft timing events. Use a timing degree wheel to check for correct camshaft installation.

For modular engines use camshaft timing kit M-6266-D46.

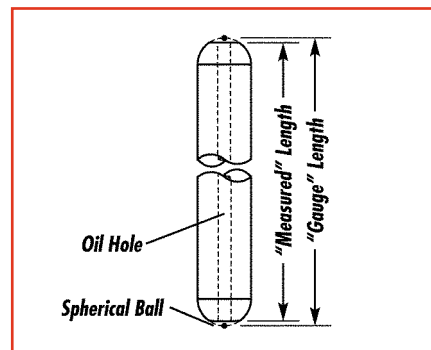

## CAMSHAFT AND LIFTER PRELUBE M-19579-A991

Looking Good isn't only what meets the eye, it includes building 'em with the right stuff, such as Ford Racing camshaft and lifter prelube. It is specially formulated with additives to withstand extreme pressures exerted on cam lobes and lifters to prevent scuffing and galling during engine break-in. Recommended for application to all hydraulic and mechanical flat tappet camshaft and lifter combinations when assembling the engine. 4-oz. container with flip-top cap.



USAC Midget Sprint Car  
Driver: Brian Olsen  
Ford Racing Performance  
Parts used:

- Midget Engine Block M-6010-A180
- Hi-Port Aluminum Head M-6049-SC1

### VALVE SPRINGS AND THINGS

Valve springs are a critical part of valve train operation. They're designed to exert a specific load at a specific installed height, thus spring selection and installation are important. A single spring is generally used for stock engines. Dual or triple springs are often necessary for performance applications to increase the load for a given installed height. If installed height isn't sufficient to handle camshaft lobe lift, coil bind may occur.

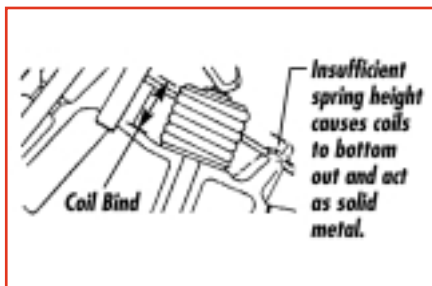

Installed Spring Height is the distance from the spring seat to the bottom of the valve retainer. Shims can be used under the spring to change spring height. If installed under stamped seat, shims and seat must have same outside diameter. Spring Seats on most production engines consist of a boss machined in the head, on which the spring pilots. On stock performance engines (302 BOSS, 351C BOSS and HO, 429 CJ/SCJ and BOSS) the head is flat and the spring sits in stamped spring seat.

Ford Racing offers spring seats for use with Ford Racing aluminum cylinder heads to prevent damage to the spring seat area.

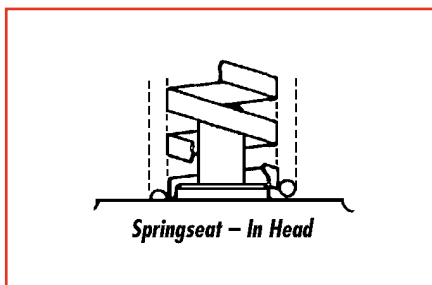
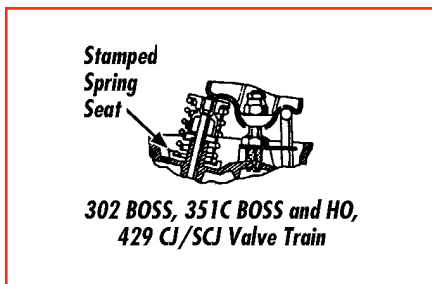

### ROCKER ARMS AND STUDS

429 BOSS, FE engines and some 4-cylinder rocker arms are shaft-mounted, while others are individually mounted (in several ways), as shown in the illustration. A non-adjustable stud is used in production engines with hydraulic cams. Mechanical camshafts require rocker arm adjustment to set valve lash (hydraulic cams with anti pump-up lifters also require adjustment).



This is a conventional rocker arm with close-tolerance slot in head to guide push rods and maintain rocker arm alignment. Can be used with mechanical or hydraulic camshafts.

USAGE: All 289 high performance and 1963-66 1/2 standard 289



Shown here is a "Rail" rocker arm with "loose-fit" hole in cylinder head for push rods. The U-shaped rocker arms maintain alignment. Can only be used with hydraulic camshafts.

USAGE: 1966 1/2-1968 standard 289 1968-76 302 and 351W

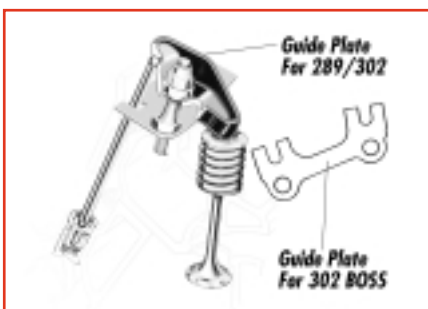

Here is a modified valve train to convert rail rocker arm design for mechanical cam. Requires conventional rocker arms, guide plates, hardened pushrods (they rub on plates) and threaded adjustable rocker studs. Requires different guide plate than the one used with a similar 302 BOSS setup.

USAGE: 289/302/351W with mechanical camshaft.

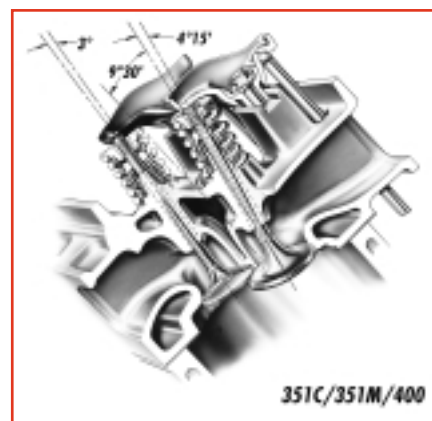
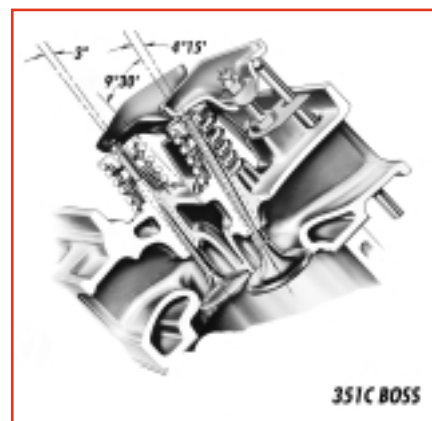

The illustration above is typical of 351C-351M-400 canted valve engines (429-460 engines are similar). The rocker arm is mounted on a slotted pedestal, moves on a "sled" fulcrum, and is retained by a bolt. 351C BOSS engines use the 302 BOSS type valve train (also used on 429 CJ/SCJ), 1968-72 429/460 with hydraulic camshafts use a screw-in positive stop stud. 1973 and later 429/460 have the 351C-type slotted pedestal.

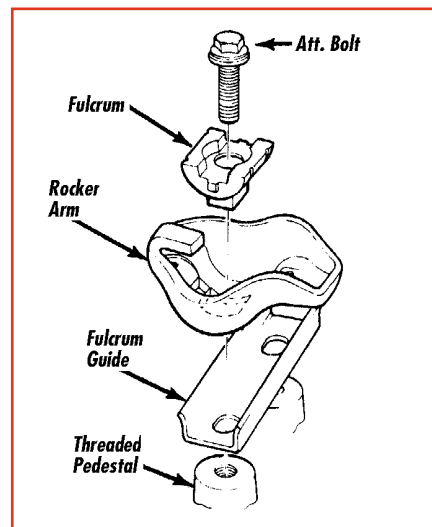

A modified pedestal is used on 1978 and later 302/351W engines. A stamped fulcrum guide is used with each pair of rocker arms.

# ENGINE BUILDING TIPS AND SPECS

## ROCKER STUD COMPARISON

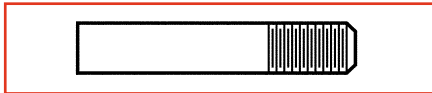

Press-in stud with adjustable rocker nut. NOT recommended with mechanical camshafts.

USAGE: Standard 289 and 1968 302

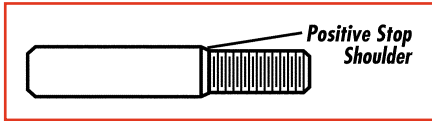

Press-in positive stop stud. Cannot be adjusted to set lash with mechanical camshaft.

USAGE: 1969-76 302/351W

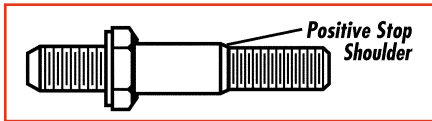

Screw-in, positive stop stud.

USAGE: 1968-72 429 with hydraulic camshaft

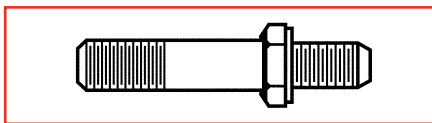

Screw-in, adjustable stud. Required for mechanical camshaft (and hydraulic with anti-pump-up lifters).

USAGE: 289 Hi-Performance, 302 BOSS, 351C BOSS and HO and 429 CJ/SCJ

## CYLINDER HEAD WATER PASSAGE MODIFICATION

As described on page 154, cylinder heads for 351C/351M/400 engines have a water outlet passage in the combustion face, whereas 289/302/351W heads have a water outlet passage in the intake manifold face of the head. Heads can be interchanged, if provision is made for appropriate water passages.

## TO INSTALL CLEVELAND TYPE HEADS (351C/351M/400) ON A WINDSOR TYPE BLOCK (289/302/302 BOSS/351W)

1. Drill a 0.800" diameter hole in the intake manifold face of the head as illustrated.
2. Plug square hole in cylinder head. Install heads with Cleveland type head gasket.
3. Use intake manifold gasket to match intake manifold.

NOTE: If BOSS type heads (302 or 351C) are used in either procedure, remember they have larger rounded ports than conventional heads; thus a unique BOSS type intake manifold gasket is required.

## ...AND IF YOU HAVE 302/351 FORD RACING ALUMINUM HEADS ①

These heads come with a tapped .75" pipe thread hole in the combustion face, but no hole in the intake manifold face.

If your application requires external water outlets, see diagram below.

## TO INSTALL ON WINDSOR TYPE BLOCK (289/302/302 BOSS/351W)

1. Install pipe plug in hole. Finish so it doesn't protrude above head face.
2. Drill a 0.800" diameter hole in the intake face as shown or use the .75" pipe thread external water outlet valve provided in the front and rear ends of Ford Racing heads produced after July, 1984.

## TO INSTALL ON CLEVELAND TYPE BLOCK (351C/351M/400)

1. Requires no special head work.

NOTE: ① Heads produced after 6/1/85 do not have .75" pipe threads at front and rear of head face and must be drilled and tapped as shown in illustration.

WATER TRANSFER MOLE LOCATION FOR 289/302 BOSS/351W



COMBUSTION FACE - FORD RACING HEAD



INTAKE FACE - FORD RACING HEAD



TYPICAL FORD RACING ALUMINUM HEADS DRILLED & TAPPED FOR EXTERNAL WATER OUTLETS  
Top Drill 1.06 Deep 1/4"-14 NPTF Thread 2-Holes

## HEAD MODIFICATION FOR MECHANICAL CAM

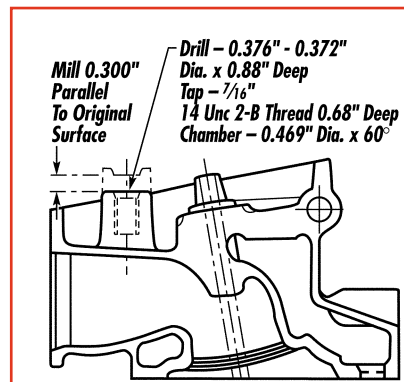

Pedestal type cylinder heads for hydraulic cams can be modified to accept a mechanical cam (351C/351M/400 shown). Machine at right angles to the existing hole — not the bottom of the head. The valves operate at compound angles. With 302/351W type pedestals, measure from the top of the pedestal.

All 302/351W	.230"
All 351C/351M/400	.300"
1973-95 429/460	.300"
1968-72 429/460	.230"

## BORING AND STROKE FUNDAMENTALS

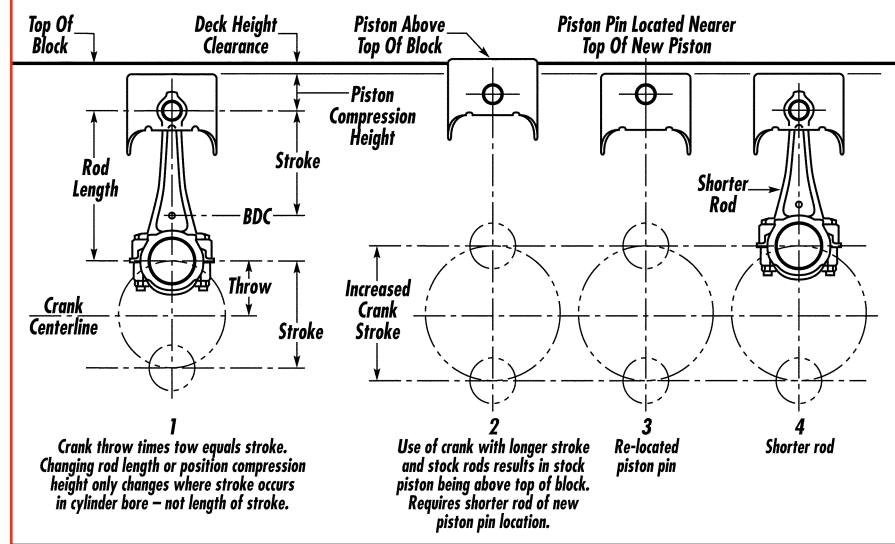

1 Crank throw times two equals stroke. Changing rod length or position compression height only changes where stroke occurs in cylinder bore — not length of stroke.

2 Use of crank with longer stroke and stock rods results in stock piston being above top of block. Requires shorter rod of new piston pin location.

3 Re-located piston pin  
4 Shorter rod