

GENERAL NOTES:

DESIGN CONTENT SHALL REMAIN THE INTELLECTUAL PROPERTY OF FORD MOTOR COMPANY. DESIGN INTENT SHALL BE EXECUTED PER DIRECTION OF FORD MOTOR COMPANY ENGINEERING. CHANGES IN MATERIALS, ASSEMBLY OR PROCESS MUST BE APPROVED PRIOR TO INITIAL PRODUCTION.

WHILE DRAWING MAY NOT REFLECT CURRENT ENGINEERING INTENT, SUPPLIER WILL BUILD ALL PARTS TO ALL NOTED ENGINEERING DIRECTION. DRAWING WILL BE UPDATED AS REQUIRED.

APPLICATION OF CONVOLUTE TUBING OR SIMILAR PROTECTIVE COVERINGS TO BE WRAPPED AND SECURED WITH APPROPRIATE TAPE WHERE REQUIRED. SUPPLIER RESERVES THE RIGHT TO CHOOSE CONVOLUTE ID BASED ON BUNDLE DIAMETER, WITHOUT ADVERSLY AFFECTING FIT, FUNCTION OR APPEARANCE.

ALL SPLICES TO BE COVERED WITH DUAL-WALL, ADHESIVE-LINED, HEAT-SHRINK TUBING.

BASE WIRE COLOR AND STRIPE SHALL BE APPLIED AS SHOWN ON DRAWING. SUPPLIER RESERVES THE RIGHT TO SUBSTITUTE OR ELIMINATE WIRE STRIPE WHILE MAINTAINING WIRE BASE COLOR.

THIS DRAWING HAS BEEN PREPARED BY OR ON BEHALF OF FORD MOTOR COMPANY AND RETAINS ALL COMMON LAW, STATUTORY AND OTHER RESERVED RIGHTS, INCLUDING COPYRIGHTS. THIS DRAWING SHALL NOT BE USED FOR ANY OTHER PURPOSE OTHER THAN PERFORMING SERVICES DIRECTLY OR INDIRECTLY TO FORD MOTOR COMPANY, WITHOUT THE EXPRESSED WRITTEN PERMISSION OF FORD MOTOR COMPANY. UNAUTHORIZED USE, COPYING OR MODIFICATION, INCLUDING THE REMOVAL OF THIS NOTE, MAY CONSTITUTE A VIOLATION OF CIVIL OR CRIMINAL LAWS, ENFORCABLE BY FORD OR GOVERNMENTAL AGENCIES.  
COPYRIGHT FORD MOTOR COMPANY (2010)

No. <b>M-14A005-FR500C</b>					
REV	REVISIONS				
	DATE	DESIGNER	CHECKED BY	APPROVAL	CAD
<b>A1</b>	NEW FORMAT DRAFT ADDED JUMPER ADAPTER NOTATION FOR CJ AND BOSS VEHICLES				
	2012.08.29	S. ALTHERR	J. DUNNE		YES
<b>A2</b>	UPDATES FOR CJ AND BOSS				
	2012.03.04	S. ALTHERR	J. DUNNE		YES

MODEL DESCRIPTION <b>2013 FR500 MUSTANG - COBRA JET/GRAND AM</b>			
PART MUST COMPLY WITH MATERIAL SPECIFICATION WSS-M99P9999-A1 TO HELP SAFEGAURD HEALTH, SAFETY AND THE ENVIRONMENT.			
DRAFTED IN ACCORDANCE WITH FAO ENGINEERING DRAFTING STANDARD CURRENT AT INITIAL RELEASE		ALL DIMENSIONS IN MILLIMETERS UNLESS OTHERWISE SPECIFIED	
CAD TYPE MS - VISIO	CAD LOCATION DRP	REFERENCE DRAWING M-14A005-FR500B	E COPY IS MASTER
DRAWING <b>M-14A005-FR500C</b>			
DESIGNER J. DUNNE	APPROVAL	TITLE <b>FR500 MUSTANG WIRING ASSEMBLY - BODY MAIN</b>	
CHECKER J. DUNNE	SAFETY N/A		
SCALE N/A	DATE 2012.08.28		
		DIVISION N/A	
		PLANT EWDMA	

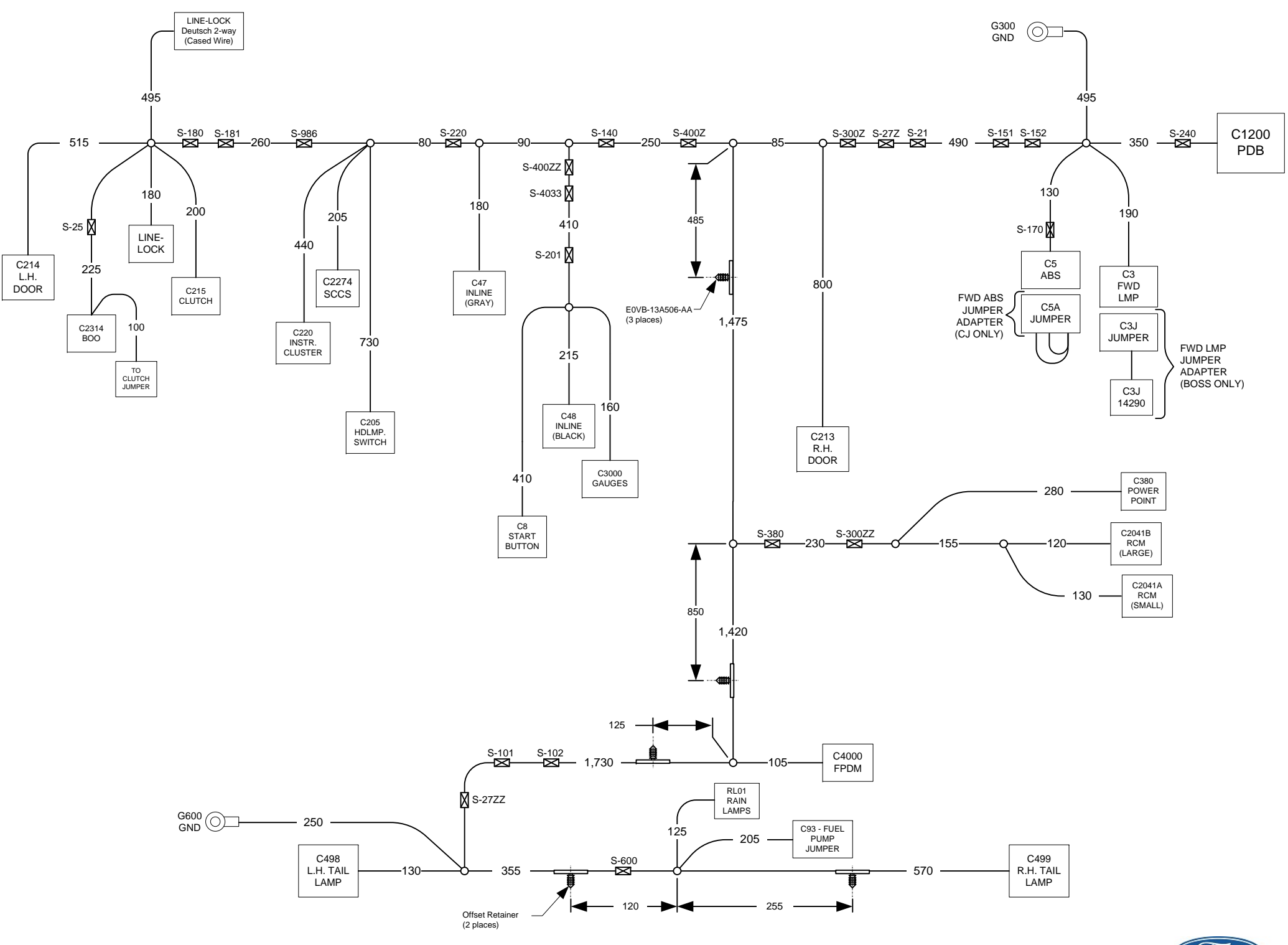

# FR500C JUMPER ADAPTERS

## CJ Cars Only

### C5A Jumper to be engaged to C5 Connector (For Brake Lamps)

(Female Terminals)

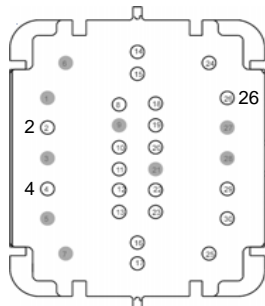

Note: Harness Ships with C5A Jumper  
Remove C5A Jumper if using ABS Harnesses 14290 & 14291

Cavity	Wire	Circuit Function	Circuit	To Connector-Pin
2	OR	STOP LAMP L.R.	101A	C5A-26 DBL Crimp
4	BN	STOP LAMP R.R.	102A	C5A-26 DBL Crimp
26	OG+BN	BRAKE ON/OFF - BOO	101A+102A	C5A - 2+4

## 2013 Boss Cars Only

### For Connection from Main Body Harness to Forward Lamp (14290)

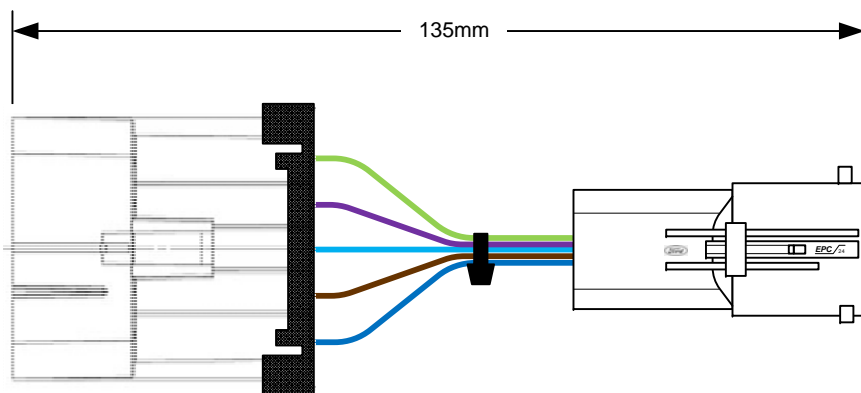

### C3 – Female Inline to Body Connector (Male Terminals)

Cavity	Wire	Circuit Function	Circuit	To Connector-Pin
2	DB/WH	HIGH BEAM	22A	C3J-A
3	BN/LB	LOW BEAM	23A	C3J-B
4	LB/BN	RF TURN LAMP	184	C3J-C
7	VT/WH	RUNNING LAMPS	27A	C3J-D
8	LG	LF TURN LAMP	183	C3J-E

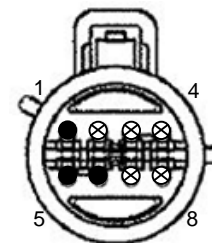

### C3J – Male Inline to Forward Lamp / Front ABS (Female Terminals)

Cavity	Wire	Circuit Function	Circuit	To Connector-Pin
A	DB/WH	HIGH BEAM	22A	C3-2
B	BN/LB	LOW BEAM	23A	C3-3
C	LB/BN	RF TURN LAMP	184	C3-4
D	VT/WH	RUNNING LAMPS	27A	C3-7
E	LG	LF TURN LAMP	183	C3-8

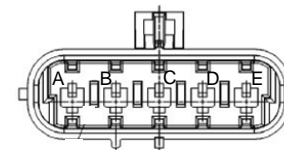

### C1200 – 42way Female Inline to PDB (Male Terminals)

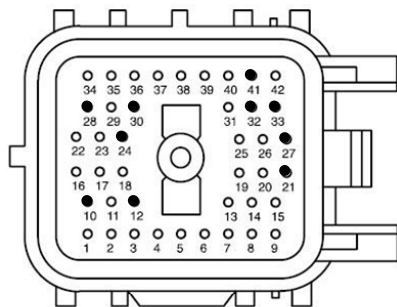

Cavity	Wire	Circuit Function	Circuit	To Connector-Pin	
1	YE	14	ABS POWER (F10 - HAAT - 30A)	120	C5-14
2	DB/WH	20	LOW BEAM RELAY – COIL HIGH (R2-1+DIODE)	24	C205-7
3	DB/RD	18	T1-12V (F3 – HAAT – 20A)	200	C48-1
4	DB	18	MASTER WINDOW SWITCH (F - 15A)	140A	S140
5	GY/RD	16	POWER POINT/LINE-LOCK	380A	S380
6	DB/WH	18	HIGH BEAM	22	C3-2
7	BN/LB	18	LOW BEAM	23	C3-3
8	GY/RD	14	RH POWER WINDOWS MOTOR	40	C213-D6
9	VT	12	ABS POWER 40A	110	C5-25
10	-	-	-	-	-
11	GY	20	PARKING LAMP – SIGNAL COIL	25A	S25
12	-	-	-	-	-
13	PK	20	MIRROR 7.5A HAAT	270	C214-B12
14	DB/WH	20	HIGH BEAM / FTP	21B	S21
15	DB/WH	20	HIGH BEAM / FTP	21C	S21
16	RD/LG	18	RUN/START – IGNITION ON	201A	S201
17	YE	18	T4-AUX 1, 12V HAAT	230	C48-9
18	RD	18	T5-AUX 2, 12V KEY ON	170A	S170
19	DB/BN	20	5A RUN/START IC	171	C220-3
20	RD	18	T5-AUX 2, 12V KEY ON	250	C48-10
21	-	-	-	-	-
22	VT	18	10A RUN/START	240A	S240
23	DB/OG	20	10A RUN/START	241	C2041A-13
24	RD	18	T6 – AUX 3, 12V KEY ON	260	C48-13
25	YE	18	BRAKE ON/OFF - BOO (F25 – HAAT – 20A)	180A	S181
26	YE/RD	20	X (F? – HAAT - 10A)	220A	S220
27	-	-	-	-	-
28	-	-	-	-	-
29	YE/RD	14	LH POWER WINDOWS MOTOR	50	C214-D6
30	-	-	-	-	-
31	VT/WH	20	PARKING LAMP POWER	27A	S27z
32	-	-	-	-	-
33	-	-	-	-	-
34	VT	14	WIPER 30A	70	C5-24
35	BK	18	GND-HIGH BEAM RL COIL (-)	300B	S300z
36	BK	20	GND-PARK/RUN LAMPS COIL (-)	300C	S300z
37	BK	20	GND-12V RUN/START RL COIL (-)	300D	S300z
38	BK	20	GND-LOW BEAM RL OFF COIL (-)	300E	S300z
39	BK	18	GND-LOW BEAM RL OFF GND PASS THRU	300H	S300z
40	BK	18	GND-SCICP RL COIL (-)	300J	S300z
41	-	-	-	-	-
-	-	-	-	-	-

Note: Twisted Pairs are highlighted in YELLOW

Note: Double-Crimps are highlighted in GREEN

Note: Circuit Function 'HAAT' describes a 12V signal that is 'Hot At All Times'.

### C5 – Female Inline to Rear ABS

(Male Terminals)

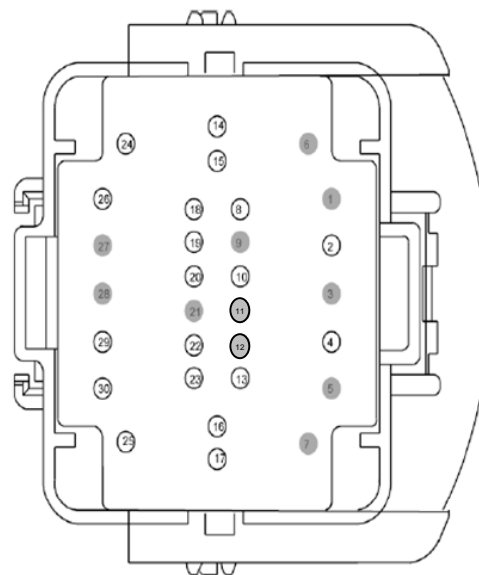

Cavity	Wire	Circuit Function	Circuit	To Connector-Pin
2	OR	18	L.R. Stop/Turn Lamp	101A S101
4	BN	18	R.R. Stop/Turn Lamp	102A S102
8	VT	18	ABS 5amp (12V Run/Start)	240C S240
10	VT	18	SPS 5amp (12V Run/Start)	240B S240
13	RD	18	Wiper Motor 5amp	170C S170
14	YE	14	ABS Power 30amp (HAAT)	120 C1200-1
15	BK	18	GND	300F S300Z
16	YE	18	Flasher 30amp (HAAT)	180B S180
18	DB/WH	18	High Beam/Flash to Pass	21A S21
19	RD	18	Power for Multi	170B S170
22	DB/WH	20	ABS/RCM CAN High	153 C2041B-20 TP 22+23
23	DG/OR	20	ABS/RCM CAN Low	154 C2041B-19 TP 22+23
24	VT	14	Wiper Motor 30amp	70 C1200-34
25	VT	12	ABS Power 40amp	110 C1200-9
26	VT	20	BRAKE ON/OFF - BOO to ABS	181A S181
27	LG	18	R.F. Turn Lamp	184 C3-8
28	LB/BN	18	L.F. Turn Lamp	183 C3-4
29	WH/DB	20	HS CAN High	151B S151 TP 29+30
30	WH	20	HS CAN Low	152B S152 TP 29+30

### C2041B – RCM, Large (Female Terminals)

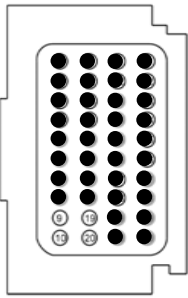

Cavity	Wire		Circuit Function	Circuit	To Connector-Pin
9	WH	20	HS CAN (-)	152A	S-152 TP 9+10
10	WH/LB	20	HS CAN (+)	151A	S-151 TP 9+10
19	DG/OG	20	ABS/RCM CAN (-)	154	C5-23 TP 19+20
20	DB/WH	20	ABS/RCM CAN (+)	153	C5-22 TP 19+20

### C220 – Instrument Cluster (Female Terminals)

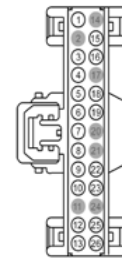

Cavity	Wire		Circuit Function	Circuit	To Connector-Pin
1	YE/RD	20	10A HAAT	220B	S-220
3	DB/BN	20	5A RUN/START	171	C1200-19
5	BK	20	GND	3400J	S-3400Z
8	BK	20	GND	3400D	S-3400Z
12	WH	20	HS CAN LOW	152D	S-152
13	WH/LB	20	HS CAN HIGH	151D	S-151
15	YE/VT	20	SENSOR – FUEL LEVEL 1 (FLI)	1111	C4000-2
16	LG/VT	20	SENSOR FUEL LEVEL 1 RETURN	3222	C4000-1
18	GN/OG	20	SENSOR – FUEL LEVEL 2 (FLI)	2333	C4000-4
19	WH/PK	20	SENSOR FUEL LEVEL 2 RETURN	3333	C4000-3

### C2041A – RCM, Small (Female Terminals)

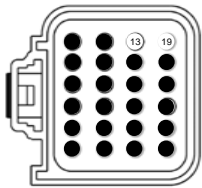

Cavity	Wire		Circuit Function	Circuit	To Connector-Pin
13	DB/OG	20	10A RUN/START	241	C1200-23
19	GY/OG	20	EVENT NOTIFICATION SIGNAL (ENS)	113	C4000-7

### C47 – Female Inline to 14A006, Controls Pack Harness (Male Terminals)

**GRAY**

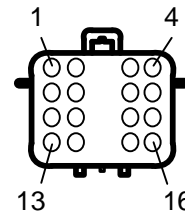

Cavity	Wire		Circuit Function	Circuit	To Connector-Pin
1	LG/BK	20	Fuel Pump Relay	4033C	S-4033
2	RD/LB	18	SMR	202	C8-2
3	RD/LG	18	ISP-R	201D	S-201
4	BK/PK	20	T3 – SCICIP Override	401	C48-5
5	PK/LG	20	HS CAN Low	S152	S-152 TP 5+6
6	WH/LG	20	HS CAN High	S151	S-151 TP 5+6
7	TN/YE	20	Tach Circuit	3000	C3000-3
8	LB/YE	20	CPP-BT	1000	C215-1
9	DG/BN	20	SCCS-RTN	3100	C2273-2
10	WH	20	SCCS	3110	C2273-3
11	VT	20	BOO	181C	S-181
12	LG/VT	20	CPP-TT	1010	C215-2
13	DG	14	Fuel Pump Feed	938A	S-938
14	DG	14	Fuel Pump Feed	938B	S-938
15	YE/DG	20	Fuel Pump Comm (FPC)	225	C4000-5
16	BN/WH	20	Fuel Pump Monitor (FPM)	318	C4000-6

### C213 – Passenger Door (Female Terminals)

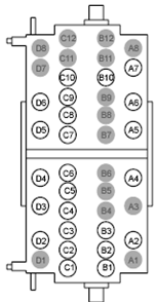

Cavity	Wire		Circuit Function	Circuit	To Connector-Pin
B1	YE/VT	20	PASSENGER MIRROR UP/DOWN	271	C214-B1
B2	BN/VT	20	PASSENGER MIRROR LEFT/RIGHT	272	C214-B2
B3	GY	20	WINDOW MOTOR	273	C214-D4
B10	DB	18	ACCESSORY DELAY RELAY	140B	S-140
D2	BN/YE	20	WINDOW SWITCH UP	41	C214-B8
D3	BK	14	GND	3400B	S-3400
D4	DG/OG	20	WINDOW SWITCH DOWN	42	C214-B7
D6	GY/RD	14	RH POWER WINDOW MOTOR	40	C1200-8

### C48 – Male Inline to Switch Panel (Female Terminals)

**BLACK**

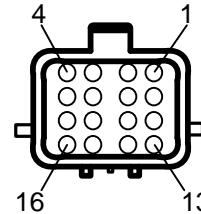

Cavity	Wire		Circuit Function	Circuit	To Connector-Pin
1	DB/RD	18	T1-12V HAAT	200	C1200-3
2	RD/LG	18	T1-IGNITION ON, 12V FEED	201C	S-201
3	RD/LG	18	T2-FUEL PUMP, 12V FROM T1	201E	S-201
4	LG/BK	20	T2-FUEL PUMP, 12V FEED	4033A	S-4033
5	BK/PK	20	T3-SCICIP OVERRIDE	401	C47-4
6	BK	20	T3-SCICIP OVERRIDE GND	3400L	S-3400ZZ
7	BK	20	IGNITION LAMP (AMBER), GND	3400M	S-3400ZZ
8	RD/LG	18	IGNITION LAMP (AMBER), 12V	201G	S-201
9	YE	18	T4-AUX 1, 12V HAAT	230	C1200-17
10	RD	18	T5-AUX 2, 12V KEY ON	250	C1200-20
11	GN/BK	20	FUEL PUMP LAMP (GREEN), 12V	4033B	S-4033
12	BK	20	FUEL PUMP LAMP (GREEN), GND	3400N	S-3400ZZ
13	RD	20	T6-AUX 3, 12V KEY ON	260	C1200-24
14	~	~	~	~	~
15	~	~	~	~	~
16	BK	20	SCICIP LAMP (BLUE), GND	3400P	S-3400ZZ

### C214 – Driver Door (Female Terminals)

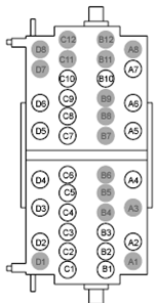

Cavity	Wire		Circuit Function	Circuit	To Connector-Pin
A3	DB	18	ACCESSORY DELAY RELAY	140C	S-140
B1	YE/VT	20	PASSENGER MIRROR UP/DOWN	271	C213-B1
B2	BN/VT	20	PASSENGER MIRROR LEFT/RIGHT	272	C213-B2
B7	DG/OG	20	WINDOW SWITCH DOWN	42	C213-D4
B8	BN/YE	20	WINDOW SWITCH UP	41	C213-D2
B12	PK	20	MIRROR 7.5A HAAT	270	C1200-13
D3	BK	14	GND	3500C	S-3500
D4	GY	20	WINDOW MOTOR	273	C213-B3

### C498 – Left Tail Lamp (Male Terminals)

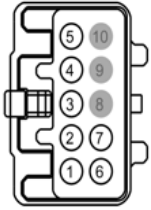

Cavity	Wire		Circuit Function	Circuit	To Connector-Pin
2	VT/WH	20	PARK LAMP	27D	S-27ZZ
3	OG	18	OUTER STOP/TURN	101B	S-101
4	OG	18	MIDDLE STOP/TURN	101C	S-101
5	OG	18	INNER STOP/TURN	101D	S-101
6	BK	16	GND	600C	S-600

### C499 – Right Tail Lamp (Male Terminals)

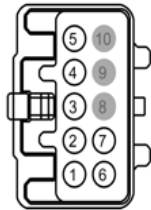

Cavity	Wire		Circuit Function	Circuit	To Connector-Pin
2	VT/WH	20	PARK LAMP	27E	S-27ZZ
3	BN	18	OUTER STOP/TURN	102B	S-102
4	BN	18	MIDDLE STOP/TURN	102C	S-102
5	BN	18	INNER STOP/TURN	102D	S-102
6	BK	16	GND	600B	S-600

### C205 – Headlamp Switch (Female Terminals)

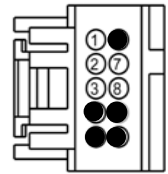

Cavity	Wire		Circuit Function	Circuit	To Connector-Pin
1	GY	20	IP/SWITCH ILLUMINATION	25C	S-25
2	GY	20	PARKING LAMP SIGNAL	25B	S-25
3	YE/RD	20	10A HAAT	220C	S-220
7	BU/WH	20	LOW BEAM SIGNAL	24	C1200-2
8	BK	20	GND	500B	S-500

### C4000 – FPDM 'A1' Connector (for Returnless Fuel System)

(Female Terminals)

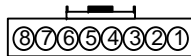

Cavity	Wire		Circuit Function	Circuit	To Connector-Pin
1	LG/VT	20	SENSOR FUEL LEVEL 1 RETURN	3222	C220-16
2	YE/VT	20	SENSOR – FUEL LEVEL 1 (FLI)	1111	C220-15
3	WH/PK	20	FUEL LEVEL 2 RETURN	3333	C220-19
4	DG/OG	20	SENSOR – FUEL LEVEL 2 (FLI)	2333	C220-18
5	YE/OG	20	FUEL PUMP COMMUNICATION (FPC)	225	C47-15
6	BN/WH	20	FUEL PUMP MONITOR (FPM)	518	C47-16
7	GY/OG	20	EVENT NOTIFICATION SIGNAL (ENS)	113	C2014A-19
8	~	~	~	~	~

### C3 – Male Inline to Forward Lamp / Front ABS (Female Terminals)

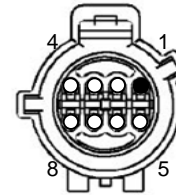

Cavity	Wire		Circuit Function	Circuit	To Connector-Pin
~	~	~	~	~	~
2	DB/WH	18	HIGH BEAM	22	C1200-6
3	BN/LB	18	LOW BEAM	23	C1200-7
4	LB/BN	20	LF TURN LAMP	183	C5-28
5	GY	20	WSS RF HIGH	1600	C5-11
6	GY/OG	20	WSS RF LOW	1601	C5-12
7	VT/WH	18	RUNNING LAMPS	27B	S-27Z
8	LG	18	RF TURN LAMP	184	C5-27

TP 5+6  
TP 5+6

### C8 – Start Button (Female Terminals)

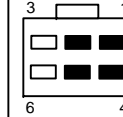

Cavity	Wire		Circuit Function	Circuit	To Connector-Pin
3	RD/LB	18	SMR	202	C47-2
6	RD/LG	18	12V Run/Start	201B	S201

### C2273 – Speed Control - SCCS (Female Terminals)

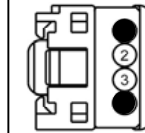

Cavity	Wire		Circuit Function	Circuit	To Connector-Pin
1	~	~	~	~	~
2	DG/BN	20	SCCS RETURN	3100	C47-9
3	WH	20	SCCS	3110	C47-10
4	~	~	~	~	~

### C2314 – Brake Switch (BOO) (Female Terminals)

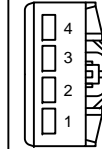

Cavity	Wire		Circuit Function	Circuit	To Connector-Pin
1	YE	18	HAAT	180C	S-180
2	BK	18	GND (CPP-TT)	3400L	S-3400z
3	YE	18	CPP-TT	180E	BS01 (SPADE)
4	VT	18	BOO	181B	S-181

### C215 – Inline to Clutch (Male Terminals)

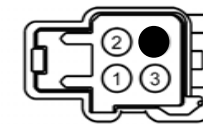

Cavity	Wire		Circuit Function	Circuit	To Connector-Pin
1	LB/YE	20	CPP-BT	1000	C47-8
2	LG/VT	20	CPP-TT	1010	C47-12
3	BK	20	GND	3400E	S-3400Z
~	~	~	~	~	~

### C3000 – Inline to Gauges (Female Terminals)

(Light Green)

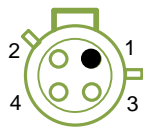

Cavity	Wire	Circuit Function	Circuit	To Connector-Pin
1	~	~	~	~
2	RD/GN	18	12V RUN/START	201F
3	TN/YE	20	TACH	3000
4	BK	20	GND	3400H
				S-201 C47-7 S-3400z

### C22 – Line-Lock Device (Female Terminals)

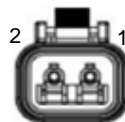

Cavity	Wire	Circuit Function	Circuit	To Connector-Pin
1	RD	20	LINE LOCK (Cased Wire)	381
2	BK	20	GND (Cased Wire)	3400L
				C24-2 S-3400z

### C380 – Power Point (Female Terminals)

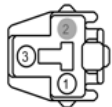

Cavity	Wire	Circuit Function	Circuit	To Connector-Pin
1	GY/RD	16	POWER POINT/LINE-LOCK SPLICE	380B
~	~	~	~	~
3	BK	16	GND POWER POINT	300K
				S-380 ~ S-300ZZ

### C93 – 2-way Inline to Fuel Pump Jumper (14407) (Female Terminals)

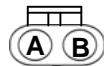

Cavity	Wire	Circuit Function	Circuit	To Connector-Pin
A	DG	18	FUEL PUMP (FPDM) 12V	938C
B	BK	18	FUEL PUMP GND	600D
				S-938 S-600

### C24 – Line-Lock Button (Female Terminals)



Cavity	Wire	Circuit Function	Circuit	To Connector-Pin
1	YE	18	LINE LOCK (Power)	180D
2	RD	18	LINE LOCK (Cased Wire)	381
				S-180 C22-1

### RL01 – Rain Lamp (Pink Female Spade)



Cavity	Wire	Circuit Function	Circuit	To Connector-Pin
~	VT/WH	18	RUNNING LAMPS – RAIN LAMP	27G
				S-27ZZ

### BS01 – BOO (Pink Female Spade)



Cavity	Wire	Circuit Function	Circuit	To Connector-Pin
~	YE	20	CPP-TT	180E
				C2314-3

### S21 – High Beam/FTP Splice

Cavity	Wire			Circuit Function	Circuit #	To	
	Color	Gauge	T/P			Connector	Pin
	DB/BK	20		High Beam / FTP	21A	C5	18
	DB/BK	20		High Beam / FTP	21B	C1200	14
	DG/BK	20		High Beam / FTP	21C	C1200	15

### S25 – Parking Lamp Signal Splice

Cavity	Wire			Circuit Function	Circuit #	To	
	Color	Gauge	T/P			Connector	Pin
	GY	20		Parking Lamp Signal - Coil	25A	C1200	11
	GY	20		Parking Lamp Signal	25B	C205	2
	GY	20		Switch Illumination	25C	C205	1

### S27z – Parking Lamp Power Splice Front

Cavity	Wire			Circuit Function	Circuit #	To	
	Color	Gauge	T/P			Connector	Pin
	VT/WH	20		Running Lamp Relay Pwr.	27A	C1200	31
	VT/WH	20		Running Lamp Pwr.	27B	C3	7
	VT/WH	20		Running Lamp Pwr.	27C	S27zz	
	VT/WH	20		Running Lamp Pwr.	27F	C2273	4

### S27zz – Parking Lamp Power Splice Rear

Cavity	Wire			Circuit Function	Circuit #	To	
	Color	Gauge	T/P			Connector	Pin
	VT/WH	20		Running Lamp Pwr.	27C	S27z	
	VT/WH	20		Running Lamp Pwr. - Tail	27D	C498	2
	VT/WH	20		Running Lamp Pwr. - Tail	27E	C499	2
	VT/WH	20		Running Lamp Pwr. - Rain	27G	RL01	QD1

### S101 – Left Tail Lamp Splice

Cavity	Wire			Circuit Function	Circuit #	To	
	Color	Gauge	T/P			Connector	Pin
	OG	18		Left Tail Lamp Source	101A	C5	2
	OG	18		Left Tail Lamp Lead	101B	C498	3
	OG	18		Left Tail Lamp Lead	101C	C498	4
	OG	18		Left Tail Lamp Lead	101D	C498	5

### S102 – Right Tail Lamp Splice

Cavity	Wire			Circuit Function	Circuit #	To	
	Color	Gauge	T/P			Connector	Pin
	BN	18		Right Tail Lamp Source	102A	C5	4
	BN	18		Right Tail Lamp Lead	102B	C499	3
	BN	18		Right Tail Lamp Lead	102C	C499	4
	BN	18		Right Tail Lamp Lead	102D	C499	5

### S140 – Acc. Delay Relay Splice

Cavity	Wire			Circuit Function	Circuit #	To	
	Color	Gauge	T/P			Connector	Pin
	DB	18		Acc. Delay Relay	140A	C1200	4
	DB	18		Acc. Delay Relay	140B	C213	B10
	DB	18		Acc. Delay Relay	140C	C214	A3

### S151 – HS CAN High Splice

Cavity	Wire			Circuit Function	Circuit #	To	
	Color	Gauge	T/P			Connector	Pin
	WH/DB	20		HS CAN High	151A	C2041B	10
	WH/DB	20		HS CAN High	151B	C5	29
	WH/LG	20		HS CAN High	151C	C47	6
	WH/DB	20		HS CAN High	151D	C220	13

### S152 – HS CAN Low Splice

Cavity	Wire			Circuit Function	Circuit #	To	
	Color	Gauge	T/P			Connector	Pin
	WH	20		HS CAN Low	152A	C2041B	9
	WH	20		HS CAN Low	152B	C5	30
	PK/LG	20		HS CAN Low	152C	C47	5
	WH	20		HS CAN Low	152D	C220	12

### S170 – 5A R/S Power Splice

Cavity	Wire			Circuit Function	Circuit #	To	
	Color	Gauge	T/P			Connector	Pin
	RD	18		12V Key On	170A	C1200	18
	RD	18		12V Key On	170B	C5	19
	RD	18		12V Key On	170C	C5	13

### S180 – R/S Power Splice

Cavity	Wire			Circuit Function	Circuit #	To	
	Color	Gauge	T/P			Connector	Pin
	YE	18		R/S Power	180C	C2314	1
	YE	18		R/S Power	180B	C5	16
	YE	18		R/S Power	180A	C1200	25
	YE	18		R/S Power	180D	C24	1

### S181 – BOO Splice

Cavity	Wire			Circuit Function	Circuit #	To	
	Color	Gauge	T/P			Connector	Pin
	VT	18		BOO to ABS	181A	C5	26
	VT	18		BOO Switch	181B	C2314	4
	VT	20		BOO to Controls Pa	181C	C47	11

### S201 – R/S Power from Ignition Splice

Cavity	Wire			Circuit Function	Circuit #	To	
	Color	Gauge	T/P			Connector	Pin
	RD/LG	18		R/S Power to PDB	201A	C1200	16
	RD/LG	18		Ign. R/S Power	201B	C8	1
	RD/LG	18		Ign. R/S Power	201C	C48	2
	RD/LG	18		Ign. R/S Power	201D	C47	3
	RD/LG	18		Ign. R/S Power	201E	C48	3
	RD/LG	18		Ign. R/S Power	201F	C3000	2
	RD/LG	18		Ign. R/S Power	201G	C48	8

### S220 – 10A HAAT Splice

Cavity	Wire			Circuit Function	Circuit #	To	
	Color	Gauge	T/P			Connector	Pin
	YE/RD	20		10A HAAT	220A	C1200	26
	YE/RD	20		10A HAAT	220B	C220	1
	YE/RD	20		10A HAAT	220C	C205	3

### S240 – 5A R/S Power Splice

Cavity	Wire			Circuit Function	Circuit #	To	
	Color	Gauge	T/P			Connector	Pin
	VT	18		10A R/S	240A	C1200	22
	VT	18		10A R/S	240B	C5	10
	VT	18		10A R/S	240C	C5	8

### S938 – Fuel Pump Feed Splice

Cavity	Wire			Circuit Function	Circuit #	To	
	Color	Gauge	T/P			Connector	Pin
	DG	14		Fuel Pump Feed	938A	C47	13
	DG	14		Fuel Pump Feed	938B	C47	14
	DG	12		Fuel Pump Feed	938C	C93	A

### S4033 – Fuel Pump Relay Splice

Cavity	Wire			Circuit Function	Circuit #	To	
	Color	Gauge	T/P			Connector	Pin
	LG/BK	20		Fuel Pump Switch	4033A	C48	4
	LG/BK	20		Fuel Pump Indicator	4033B	C48	11
	LG/BK	20		Fuel Pump Relay	4033C	C47	1



### G300 – Ground Ring Terminal

Cavity	Wire			Circuit Function	Circuit #	To	
	Color	Gauge	T/P			Connector	Pin
RING BK		12		GND - Ring Terminal	300A	S300z	

### G600 – Ground Ring Terminal

Cavity	Wire			Circuit Function	Circuit #	To	
	Color	Gauge	T/P			Connector	Pin
RING BK		14		GND - Ring Terminal	600A	S600	

### S300z – Ground Splice

Cavity	Wire			Circuit Function	Circuit #	To	
	Color	Gauge	T/P			Connector	Pin
	BK	14		GND - Ring Terminal	300A	G300	
	BK	18		GND (High beam RL Coil I - )	300B	C1200	35
	BK	20		GND (Park/Run Lamps Coil - )	300C	C1200	36
	BK	20		GND (12V Run/Start RL Coil - )	300D	C1200	37
	BK	20		GND (Low Beam RL Off Coil - )	300E	C1200	38
	BK	18		GND (ABS Harness GND: Multi, Flasher)	300F	C5	15
	BK	16		GND (Line Lock GND Splice)	300G	S300zz	
	BK	18		GND (Low Beam RL Off GND Pass Through)	300H	C1200	39
	BK	18		GND ( SCICP RL Coil - )	300J	C1200	40

### S3400z – Ground Splice

Cavity	Wire			Circuit Function	Circuit #	To	
	Color	Gauge	T/P			Connector	Pin
	BK	14		GND ( Passenger Door Window Motor)	3400B	C213	D3
	BK	18		GND ( Splice to Splice)	3400C	S3400zz	
	BK	20		GND ( Instrument Cluster-???)	3400D	C220	8
	BK	20		GND ( Clutch )	3400E	C215	3
	BK	20		GND ( Clock Spring (SCCS) )	3400K	C2273	1
	BK	20		GND ( Gauges )	3400H	C3000	4
	BK	20		GND ( Instrument Cluster)	3400J	C220	5
	BK	20		GND – LINE LOCK – (Cased Wire)	3400L	C22	2

### S300zz – Ground Splice

Cavity	Wire			Circuit Function	Circuit #	To	
	Color	Gauge	T/P			Connector	Pin
	BK	16		GND (Splice to Splice carrier wire)	300G	S300z	
	BK	16		GND (Inline Splice)	300K	C380	3
	BK	18		GND - Cased Wire	300L	LINELOCK	-

### S3400zz – Ground Splice

Cavity	Wire			Circuit Function	Circuit #	To	
	Color	Gauge	T/P			Connector	Pin
	BK	18		GND (Splice to Splice)	3400C	S3400z	
	BK	20		GND (SCICP - OverRide)	3400L	C48	6
	BK	20		GND ( Ignition Lamp (Amber) )	3400M	C48	7
	BK	20		GND ( Fuel Pump (Green) )	3400N	C48	12
	BK	20		GND (SCICP Lamp (Blue) )	3400P	C48	16

### S600 – Ground Splice

Cavity	Wire			Circuit Function	Circuit #	To	
	Color	Gauge	T/P			Connector	Pin
	BK	14		GND ( Ring Terminal)	600A	G600	
	BK	16		GND (Right Tail Lamp)	600B	C499	6
	BK	16		GND (Left Tail Lamp)	600C	C498	6
	BK	14		GND (Fuel System)	600D	C93	B

### S3500 – Ground Splice

Cavity	Wire			Circuit Function	Circuit #	To	
	Color	Gauge	T/P			Connector	Pin
	BK	20		GND (HeadLamp SW.)	3500B	C205	8
	BK	14		GND (Driver Door Window Motor)	3500C	C214	D3

## Line Lock Circuit Schematic

**Note:**

- Circuit 381 connects the Line Lock Device to the Line Lock Button (PTT)
- Circuit 180D provides power to the Line Lock Button from splice S180
- Circuit 3400L connects the Line Lock Device to ground from splice S3400z
- Circuit 180A provides power to the Brake Switch from splice S180

